

**XUN**<sup>®</sup>  
P R O  
S T A G E  
E F F E C T S  
炫力·专业舞台特效

**DJPOWER**<sup>®</sup>



**DB-60V VERTICAL BUBBLE MACHINE**  

---

**USER MANUAL**

GUANGZHOU DJPOWER ELECTRONIC TECHNOLOGY CO.,LTD

# 1 BEFORE YOU BEGIN

## 1.1 What Is Included

DB-60V Machine × 1

W-2 wireless remote × 1

Warranty Card × 1

Power Cord × 1

Omega Bracket × 1



User Manual × 1

## 1.2 Unpacking Instructions

Carefully unpack the product immediately and check the container to make sure all the parts are in the package and are in good condition.

If the box or the contents (the product and included accessories) appear damaged from shipping, or show signs of mishandling, notify the carrier or dealer/seller immediately. In addition, keep the box and contents for inspection.

## 1.3 Symbols

Symbol	Meaning
	<b>Caution</b> Critical installation, configuration, or operation information. Not following these instructions may make the product not work, cause damage to the product, or cause harm to the operator.
	<b>Important</b> Important installation or configuration information. Failure to comply with this information may keep the product from working correctly.
	<b>Information</b> Useful information.

## 1.4 Disclaimer

The information and specifications contained in this User Manual are subject to change without notice. DJPOWER assumes no responsibility or liability for any errors or omissions and reserves the right to revise or to create this manual at any time. Copyright © 2023 DJPOWER. All rights reserved.

## 1.5 Safety Notes

Please read the following Safety Notes carefully before working with the product. The notes include important safety information about installation, usage, and maintenance.

### 1.5.1 Personal Safety

- Always connect the product to a grounded circuit to avoid the risk of electrocution.
- Make sure that children, unauthorized people and animals do not obtain access to the machine.

## 1.5.2 Mounting and Rigging



In order to prevent the liquid from splashing on the ground after the bubble bursts, causing the ground to be slippery. It's better that use a layer of absorbent cotton on the ground, when you use bubble machine and fog machine. When the machine is hang upside down, the bottom of the machine should be away from people or important items. After the machine is used, the liquid on the ground should be cleaned up in time to prevent slipping.

- The product is for indoor use only! To prevent risk of fire or shock, do not expose the product to rain or moisture.
- CAUTION: When transferring product from extreme temperature environments, (e.g. cold truck to warm humid ballroom) condensation may form on the internal electronics of the product. To avoid causing a failure, allow product to fully acclimate to the surrounding environment before connecting it to power.
- Do not mount the product on a flammable surface (linoleum, carpet, wood, paper, carton, plastic, etc.).
- Do not use in a confined space. Always install the product in a location with adequate ventilation, at least 20 in (50 cm) from adjacent surfaces.
- Be sure that no ventilation slots on the product's housing are blocked or clogged by dust. If necessary, remove the dust.

## 1.5.3 Power and Wiring

- Always make sure that the voltage of the outlet to which you are connecting the product is within the range stated on the decal or rear panel of the product.
- Make sure the power cord is not crimped or damaged.
- Never connect this product to a dimmer pack or rheostat.
- Never disconnect the product from power cord by pulling or tugging on the cord.
- To eliminate unnecessary wear and improve its lifespan, during periods of non-use completely disconnect the product from power via breaker or by unplugging it

## 1.5.4 Operation

- Do not operate this product if you see damage to the housing or cables. Have the damaged parts replaced by an authorized technician at once.
- Do not use the product as a space heater.
- The maximum ambient temperature ( $T_a$ ) is 104 °F (40 °C). Do not operate the product at higher temperatures.
- **Do not cover the ventilation slots when operating to avoid internal overheating.**
- **Do not cover or plug the output nozzle during operation.**
- Wipe up spitted fluid immediately. Moisture – also fluid – can destroy the electric.
- Never carry the product by the power cord or any moving part. Always use the handles of the machine.
- **Drain the tank before transporting the product.**
- Always disconnect the product from the power source before cleaning.

- In the event of a serious operating problem, stop using the product immediately.
- This product contains no user-serviceable parts. Any reference to servicing in this User Manual will only apply to properly trained, certified technicians. Do not open the housing or attempt any repairs which can lead to damage or malfunction.
- **Use only DJPOWER Consumable. Please use professional bubble fluid PRO-P.**



Keep this User Manual for future use. If you sell the product, be sure that the purchaser receives this document.

## 2 INTRODUCTION

### 2.1 Description

B-60V is a new vertical bubble machine launched by DJPOWER. The built-in powerful fan can create bubbles vertically up to a height of 4-5 meters. 5 PCS 8 W RGBA 4 in 1 LED, with colorful bubble effects. It's 1.3 L fluid tank for sealed storage. The high and color of bubble is adjustable. Suitable for all stage that need create bubble effects.

### 2.2 Features

- Smaller, more convenient using
- Built-in rechargeable battery, full charge last 2.5 hours
- Built- in strong fan, vertically spray bubble
- 5 PCS 8 W single LED, it's colorful bubble effects.
- Please use DJPOWER professional bubble fluid PRO-P, otherwise it might cause block and water squirting.

Note: The actual effect may be affected by the use environment.

### 2.3 Product Overview

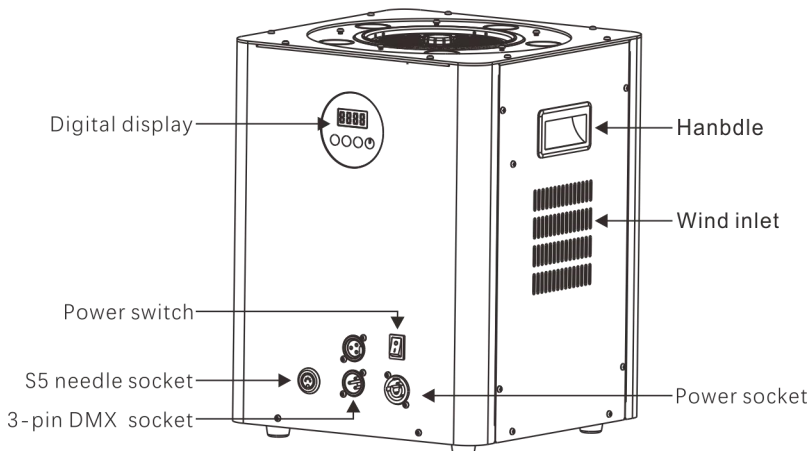

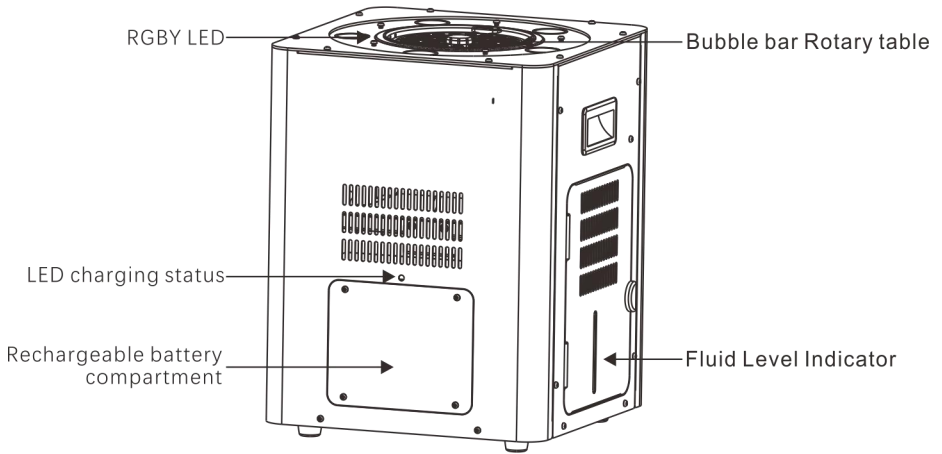

## 2.4 Product Dimensions

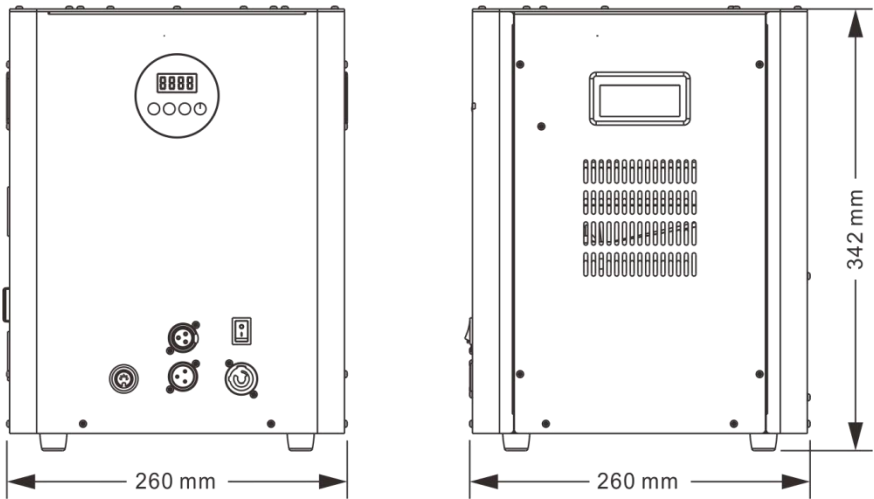

## 3 TECHNICAL SPECIFICATIONS

<b>AC Power</b>	<b>Input Voltage &amp; Rate</b>	AC 220-240 V, 50/60 Hz
	Total Power Consumption	60 W
<b>Light Source</b>	LED Color	RGBA
	LED Type	4 in 1
	Power per LED	8 W
	Quantity of LED	5 pcs
	Total LED Power	40 W

<b>Capacity</b>	Fluid Tank Capacity	1.3 L
	Spray angle	90°
<b>Output</b>	Max Output Height	Appr. 4-5 m
	Bubble Fluid Consumption Rate	Appr. 38.5 min/L
	Fully-charged Continuous Output Duration	Appr. 2.5 h
	Consumable Type for Standard Output Test	PRO-P
	Horizontal	√
<b>Placement &amp; Mounting</b>	Inclined	×
	Sidelong (Don't cover heat emission hold)	×
	Hang Upside Down	×
	Rigging & Trussing	×
	On-device Manual Control	Digital display
<b>Control</b>	Wireless Control	W-2
	Wired Control	×
	Control Protocol	DMX512
	DMX Channel Range	7
	<b>Consumable</b>	Consumable
<b>Weight &amp; Dimensions</b>	Net Weight	Appr. 7.85 kg
	Gross Weight	Appr. 9.5 kg
	Machine Dimensions	260 × 260 × 342 mm
	Packing Dimensions	336 × 336 × 405 mm

## 4 SETUP

### 4.1 AC Power

The machine has a fixed voltage power supply and can work with an input voltage of AC 220 V-240 V, 50/60 Hz, depending on the specific model.

To determine the product's power requirements (circuit breaker, power outlet, and wiring), use the current value listed on the label affixed to the product's back panel, or refer to the product's specifications chart. The listed current rating indicates the product's average current draw under normal conditions.



**Always connect the product to a protected circuit (circuit breaker or fuse). Make sure the product has an appropriate electrical ground to avoid the risk of electrocution or fire.**



**Never connect the product to a rheostat (variable resistor) or dimmer circuit, even if the rheostat or dimmer channel serves only as a 0 to 100% switch.**

## 4.2 AC Plug

The DB-60V comes with a power input cord terminated with a Seetronic PowerCon connector on one end and an EU plug on the other end (EU market). If the power input cord that came with your product has no plug, or if you need to change the plug, use the table below to wire the new plug:

<b>AC Live</b>	Black	Brown
<b>AC Neutral</b>	White	Blue
<b>AC Ground</b>	Green	Green/Yellow

## 4.3 DMX Linking

You can link the DB-60V to a DMX controller using a 3-pin DMX connection. It can be connected to the same console with other DMX-enabled devices and controlled separately. Instructions for connecting and configuring this product for DMX operation are in the User Manual.

## 4.4 Mounting

Before mounting the product, read and follow the safety recommendations indicated in the Safety Notes.

### 4.4.1 Orientation

For safety reasons, we do not recommend mounting the product in any capacity. Operate the product while it is on the ground only, and make sure there is adequate room for ventilation, configuration, and maintenance.

### 4.4.2 Rigging

DJPOWER recommends using the following general guidelines when mounting this product.

- Before deciding on a location for the product, make sure there is easy access to the product for maintenance and programming purposes.
- Make sure that the structure or surface onto which you are mounting the product can support the product's weight (see the Technical Specifications).
- When mounting the product on the floor, make sure that the product and cables are away from people and vehicles.

# 5 OPERATION

## 5.1 Preparing for Operation

- After checking that all the parts are intact and complete, position the machine on flat.
- Take out the oil tank, add bubble fluid
- Verify that the plastic hoses attached to the cap are in place and in good condition without bending or warp.
- Always connect the product to a grounded circuit. Before power on, make sure it is connected with the rated voltage.

- Turn on the machine, the digital tube display the value of battery

## 5.2 Digital tube display Control

To access the control panel functions, disconnect the DMX signal, and use the four buttons located underneath the Digital display tube.

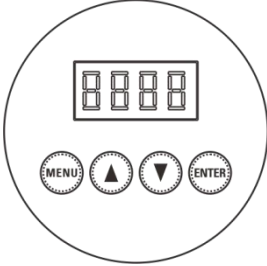

Button	Function
<MENU>	Switch menu pages to select a function
<▲>	Increases the numeric value of current function
<▼>	Decreases the numeric value of current function
<ENTER>	Save/ Quit

Standby display "≡100", it means percentage of remaining battery power:



Press:"MENU", there are 5 pages:

### 1、 "Addr "

First page, DMX address setting, press "ENTER", then press "UP" or "DOWN" set 1-512, last press "ENTER" exit menu.



### 2、 "CH-1"

The second page, LED color setting, press "ENTER", then press "UP" or "DOWN" set LED color (9 colors or close color), last press "ENTER" exit menu.



### 3、 "RENO "

The third page, remote function, press "ENTER", then press "UP" or "DOWN" set OFF/ON (open or close remote function, last press"ENTER" exit menu.



### 4、 "NODE "



The forth page, Spray bubble setting, press "ENTER", then press "UP" or "DOWN" set n1/ n2 model. The fan does not work when n1 is in standby, and the fan will continue to work when n2 is in standby, so as to achieve the effect of quickly opening the bubble spray. Last press "ENTER" exit menu.



### 5、 "OUTP"

The fifth page, bubble manual work Settings. press "ENTER", then press "UP" or "DOWN" set OFF/ON (open or close);



Operating Tips:

1.On any pages, If the button is not touched within 10S, the display will return to the "≡ 100" power display standby page



## 5.3 Wireless Remote-Control Mode & Operation

This mode will allow you to control the DB-60V using the wireless controller W-2. This consists of the transmitter and the receiver, any one(or more) W-2 transmitter can work with any one (or more) W-2 receiver, no pairing procedure needed.

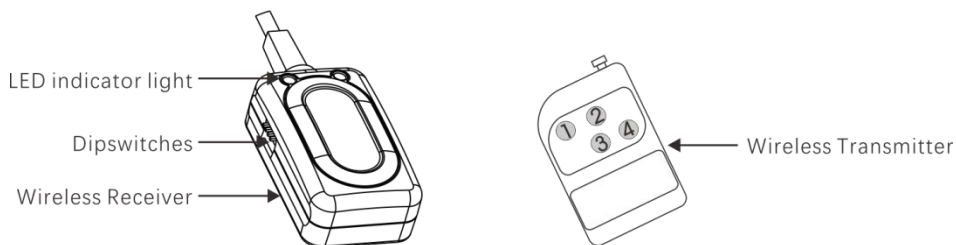

This mode will allow you to control the DB-60V using the wireless controller. It's including the transmitter and the receiver. You can control up to 4 independent machines, or many more if you run them simultaneously.

See the below instructions on setting up your operate with the wireless controller.

Plug the wires receiver into the machine 5-pin port labeled "Wireless Controller".

There are 4 buttons on the wireless remote transmitter which act as triggers. Each button can be assigned to a different machine. You may only choose 1 address switch on each receiver. See the below configuration for setting the receiver operate with the transmitter remote.

Mode Dipswitches

CH1 1 = On, 2-4 = Off

CH2 2 = On, 1,3,4 = Off

CH3 3 = On, 1,2,4 = Off

CH4 4 = On, 1,2,3 = Off

3. Press the button, and the DB-60V will run momentarily for as long as you hold down the button. Release the button, the unit stops running.

## 5.4 DMX Mode & Operation

- The machine DB-60V works with a DMX controller.
- Connect the product to a suitable power outlet
- Turn the product on.
- Connect a DMX cable from the DMX output of the DMX controller to the DMX input socket on the product.

When the machine connects to DMX, the display will always show DMX starting address, and you can set or change it at any time by pressing UP or DOWN button.

### DMX Channel Assignments and Values DMX

<b>DMX Channel</b>	1	Bubble Output	0-10 No function	11-255 ON
	2	RED	0-10 No function	11-255 Dim to bright
	3	Blue	0-10 No function	11-255 Dim to bright
	4	Green	0-10 No function	11-255 Dim to bright
	5	Amber	0-10 No function	11-255 Dim to bright
	6	Color Marco	0-10 No function	11-255 Color Marco
	7	Strobe	0-10 No function	11-255 Slow to fast

## 6 TECHNICAL INFORMATION

### 6.1 Expected LED Lifespan

LEDs gradually decline in brightness over time, primarily due to heat. Packaged in clusters, LEDs exhibit higher operating temperatures than in ideal, single-LED conditions. For this reason, using clustered LEDs at their fullest intensity significantly reduces the LEDs' lifespan. Under normal conditions, this lifespan can be 40,000 to 50,000 hours. If extending this lifespan is vital, lower the operating temperature by improving the ventilation around the product and reducing the ambient temperature to an optimal operating range. In addition, limiting the overall projection intensity may also help to extend the LEDs' lifespan.

## 6.2 Maintenance

After each time use of the bubble machine, it is necessary to clean the bubble head with clean water in time to prevent the residual bubble liquid on the bubble head from solidifying and gluing, which will cause it to fail to be used normally next time!

Do not allow the DB-60V to become clogged due to the sticky bubble fluid. Cleaning and maintenance are necessary.

The recommended cleaning procedure is as follows.

- 1) Unplug the product from power.
- 2) Empty bubble fluid from the machine.
- 3) Add water to the bubble fluid tank.
- 4) Connect the machine to the power supply, start the bubble spraying work. The machine will automatically pump clean water into the machine to clean the bubble outlet and pipes
- 5) Run the product in a well-ventilated area. Do not allow the pump to run dry.
- 6) Add bubble fluid again, run the machine briefly to remove any remaining water from the oil pump.
- 7) Excessive dust, fluid residue and dirt will degrade performance and cause overheating. Remove dust from air vents with air compressor, vacuum or soft brush. The casing could be cleaned by the damp cloth.

Note: The default cleaning time is 1 minute. Without turning of the cleaning mode manually, it will shut of automatically after 1 minute.



**Test-run your DJPOWER® DB-60V on a monthly basis to achieve the best performance.**

## 7 STORAGE

### 7.1 Machine Storage

Before storing the machine, clean it as described in the cleaning procedure above; however, only follow steps 1 through 5. Do not refill the tank with bubble fluid if storing the machine. Empty bubble fluid from the machine. Cleaning the system prior to storage will help prevent any particles from condensing inside the pump or heater while not in use.

