

TOPCAT[®]

by DJPOWER

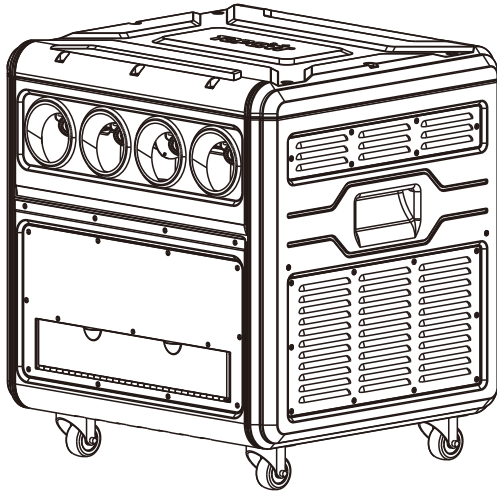

HW-IP4 SMOBBLE 4

USE MANUAL

1 BEFORE YOU BEGIN

1.1 What Is Included

HW-IP4 Smobble 4 × 1 Power cord × 1 Warranty card × 1



Note: According to the needs of different scenarios, lifting brackets can be optionally installed. (Extra charge)

1.2 Unpacking Instructions

Carefully unpack the product immediately and check the container to make sure all the parts are in the package and are in good condition.

If the box or the contents (the product and included accessories) appear damaged from shipping, or show signs of mishandling, notify the carrier or dealer/seller immediately. In addition, keep the box and contents for inspection.

1.3 Symbols

Symbol	Meaning
	Caution Critical installation, configuration, or operation information. Not following these instructions may make the product not work, cause damage to the product, or cause harm to the operator.
	Important Important installation or configuration information. Failure to comply with this information may keep the product from working correctly.
	Information Useful information.

1.4 Disclaimer

The information and specifications contained in this User Manual are subject to change without notice. DJPOWER assumes no responsibility or liability for any errors or omissions and reserves the right to revise or to create this manual at any time.

Copyright © 2024 DJPOWER. All rights reserved.

1.5 Safety Notes

Please read the following Safety Notes carefully before working with the product. The notes include important safety information about installation, usage, and maintenance.

1.5.1 Personal Safety

- Always connect the product to a grounded circuit to avoid the risk of electrocution.
- Make sure that children, unauthorized people and animals do not obtain access to the machine!

1.5.2 Mounting and Rigging



In order to prevent the liquid from splashing to the ground after the bubbles burst, causing the ground to be slippery, It is recommended to use a layer of absorbent cotton on the floor of the machine to prevent slipping. When the machine is used in a suspended position, the bottom of the machine should be kept away from people or important objects. After using, liquids scattered on the ground should be cleaned up promptly to prevent people from slipping.

- When transferring product from extreme temperature environments, (e.g. cold truck to warm humid ballroom) condensation may form on the internal electronics of the product. To avoid causing a failure, allow product to fully acclimate to the surrounding environment before connecting it to power.
- Do not mount the product on a flammable surface (linoleum, carpet, wood, paper, carton, plastic, etc.).
- Do not use in a confined space. Always install the product in a location with adequate ventilation, at least 20 in (50 cm) from adjacent surfaces.
- Be sure that no ventilation slots on the product's housing are blocked.
- When the machine is hung, please use a hanging device to securely tie it to the truss..

1.5.3 Power and Wiring

- Always make sure that the voltage of the outlet to which you are connecting the product is within the range stated on the decal or rear panel of the product.
- Make sure the power cord is not crimped or damaged
- Do not connect the machine to the dimming controller or rheostat.
- Never disconnect the product from power cord by pulling or tugging on the cord.
- To eliminate unnecessary wear and improve its lifespan, during periods of non -use completely disconnect the product from power via breaker or by unplugging it.

1.5.4 Installation Instructions

- Do not operate this product if you see damage to the housing or cables. Have the damaged parts replaced by an authorized technician at once.
- Do not use this machine as a space heater.
- Make sure there are no flammable materials close to this product while it is operating.
- The maximum ambient temperature (Ta) is 104 °F (40 °C). Do not operate the product at higher temperatures.
- Do not cover the ventilation slots when operating to avoid internal overheating.
- Do not cover or block the nozzle during operation.
- Never carry the product by the power cord or any moving part. Always use the handles.
- Drain the tank before transporting the product. Bubble fluid or the fog fluid tanks shall be used for the relevant fluid only.
- Always disconnect the product from the power source before cleaning.
- In the event of a serious operating problem, stop using the product immediately.
- This product contains no user -serviceable parts. Any reference to servicing in this User Manual will only apply to properly trained, certified technicians. Do not open the housing or attempt any repairs which can lead to damage or malfunction.
- Use only DJPOWER Consumable. Bubble fluid PRO-PW and fog fluid PRO-C are recommended.
- Please save this manual for future use. When resell the machine, be sure to attach the instruction.

2 INTRODUCTION

2.1 Description

HW-IP4 is a newly high-end jet-design rainproof 4 -nozzle bubble fog machine launched by DJPOWER. The body is made of high-strength integrated composite materials, which is light weight, rust-free, corrosion-resistant, sturdy and durable. Water-conducting structure design, waterproof grade IP54, the machine is not affected by rain when working. The 4 -nozzle design can help produce huge amount of bubbles with fog filled inside. Innovative patented Jet -design ensures fog being trapped inside bubbles, avoids too much fog dispersing in the air. The height and distance of the bubble fog can be adjusted through changing the air outlet angle. Bubble fluid is well stored and sealed in the tank without going bad even after long time to ensure high quality show. Suitable for outdoor use.

2.2 Features

- High-strength integrated composite material housing, water -conducting structure design; waterproof grade IP54; suitable for outdoor use;
- Innovative Jet design, create denser and beautiful fog bubbles, greatly reducing the formation of excess smoke;
- Well -designed heating system releases the fog evenly and purely, no fluid dropping off;
- Three fans with adjustable angles make the fog bubble fly higher, further;
- LCD color screen, easy to use.

Please use DJPOWER special bubble fluid PRO-PW and fog fluid PRO-C.

Note: The actual effect may be affected by the using environment.

2.3 Product Overview

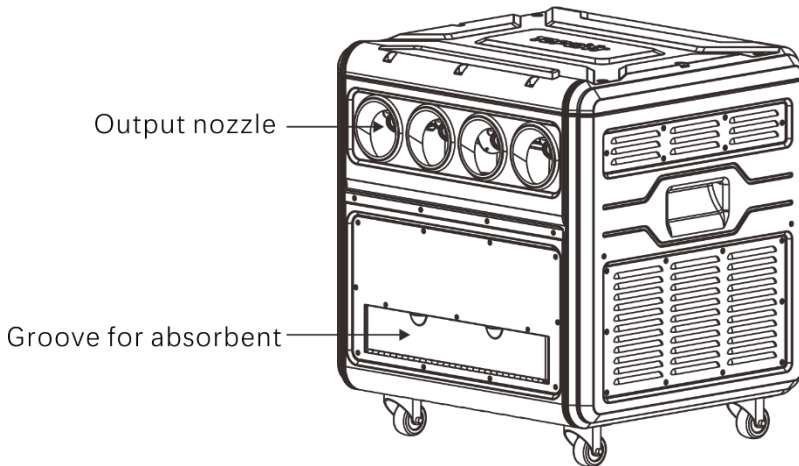

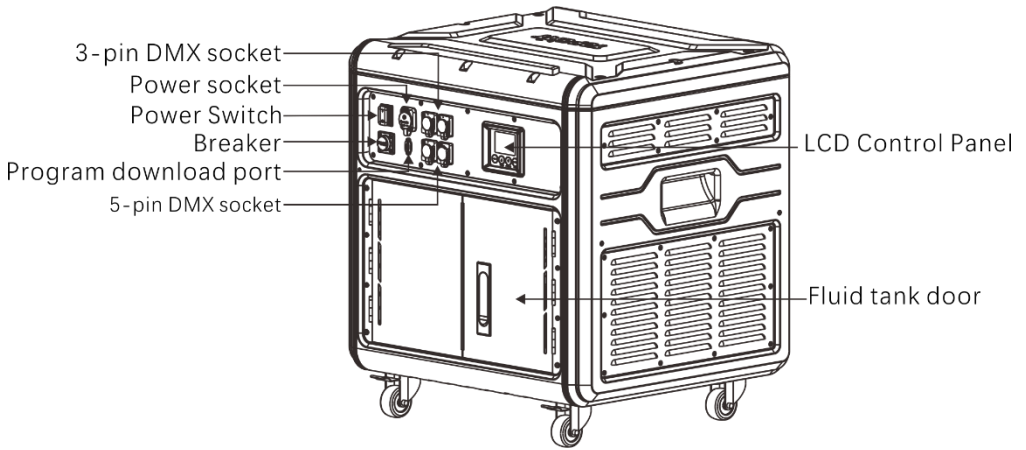

2.4 Product Dimensions

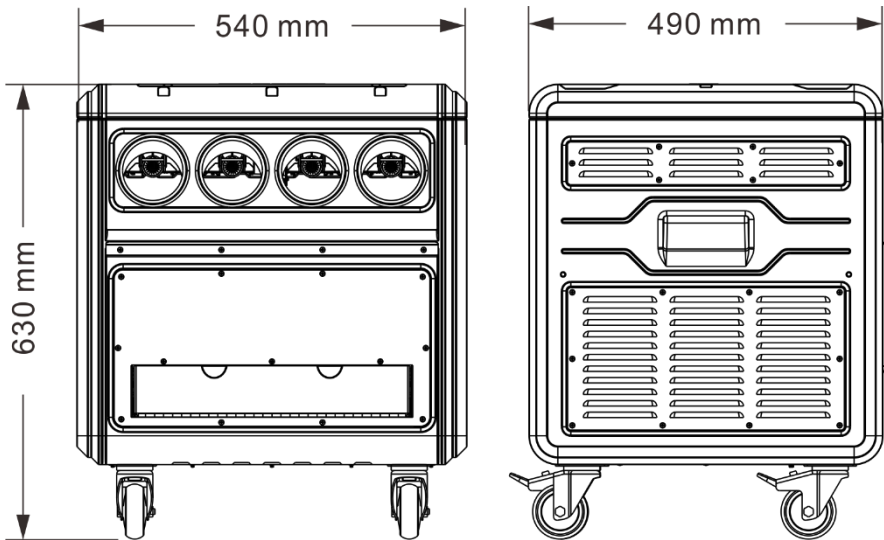

3 TECHNICAL SPECIFICATION

AC Power	Input Voltage & Rate	AC 100-120 V, 50/60 Hz	AC 220-240 V, 50/60 Hz
	Current Limiter Type	Breaker	Breaker
	Current Limiter Specifications	15 A, 250 V	10 A, 250 V
	Total Power Consumption	1,600 W	1,600 W

Heating	Heat Up Time	Appr. 3.5 min
Capacity	Bubble Fluid Tank Capacity	9 L
	Fog Fluid Tank Capacity	5 L
Waterproof	Waterproof Grade	IP54
Output	Adjustable Output	√
	Max Fog Output Volume	Appr. 6,000 cuft/min
	Max Output Height	Appr. 10 m
	Max Output Distance	Appr. 10 m
	Fog Fluid Consumption (100% Output)	Appr. 90.9 min/L
	Bubble Fluid consumption (100% Output)	Appr. 12.5 min/L
	Consumable Type for Standard Output Test	PRO-PW and PRO -C and PRO-J
Placement & Mounting	Horizontal	√
	Inclined	×
	Sidelong	×
	Hang Upside Down	×
	Rigging & Trussing	√ (Suspension brackets need extra charge)
Control	On -device Manual Control	Color screen LCD control panel
	Wireless Control	×
	Wired Control	×
	Control Protocol	DMX512
	DMX Channel Range	4
Consumable	Consumable	PRO-PW & PRO-C & PRO-J
Weight & Dimensions	Net Weight	34.5 kg
	Gross Weight	39.5 kg
	Machine Dimensions	540 × 490 × 630 mm
	Packing Dimensions	642 × 594 × 720 mm

4 SETUP

4.1 AC Power

The machine has two kinds of voltage power supply, it can work with an input voltage of AC 110 V -120 V, 50/60 Hz or AC 220 V -240 V, 50/60 Hz, depending on the specific model.

To determine the product's power requirements (circuit breaker, power outlet, and wiring), use the current value listed on the label affixed to the product's back panel, or refer to the product's specifications chart. The listed current rating indicates the product's average current draw under normal conditions.



Always connect the product to a protected circuit (circuit breaker or fuse). Make sure the product has an appropriate electrical ground to avoid the risk of electrocution or fire.

Never connect the product to a rheostat (variable resistor) or dimmer circuit, even if the rheostat or dimmer channel serves only as a 0 to 100% switch.

4.2 AC Plug

The HW-IP4 Smobble comes with a power input cord terminated with a Lockable power connector on one end. The other end is

- CN plug (CN market, etc.)
- EU plug (EU market, etc.)
- US plug (US market, etc.)

If the power input cord that came with your product has no plug, or if you need to change the plug, use the table below to wire the new plug:

:

	Wire (U.S.)	Wire (Europe)
AC Live	Black	Brown
AC Neutral	White	Blue
AC Ground	Green/Yellow	Green/Yellow

4.3 Reset Breaker

The unit is equipped with a resettable breaker. If the breaker trips, the unit will be disconnected from the power.

- Disconnect the machine from the power.
- Wait for about 15 minutes till the unit cools down.
- After that, manually press the button of the breaker to reset it.
- Reconnect the machine to the power outlet and continue to use it as recommended.

4.4 DMX Linking

You can link the machine to a DMX controller using a 3 - or 5-pin DMX connection. If using other DMX - compatible products with this product, you can control each individually with a single DMX controller. Instructions for connecting and configuring this product for DMX operation are in the User Manual.

4.5 Mounting

Before mounting the product, read and follow the safety recommendations indicated in the Safety Notes.

4.5.1 Orientation

For safety reasons, make sure the unit is well mounted through bracket and with safety cable. Also make sure there is adequate room for ventilation, configuration, and maintenance.

 **Do not mix bubble fluid and fog fluid.**

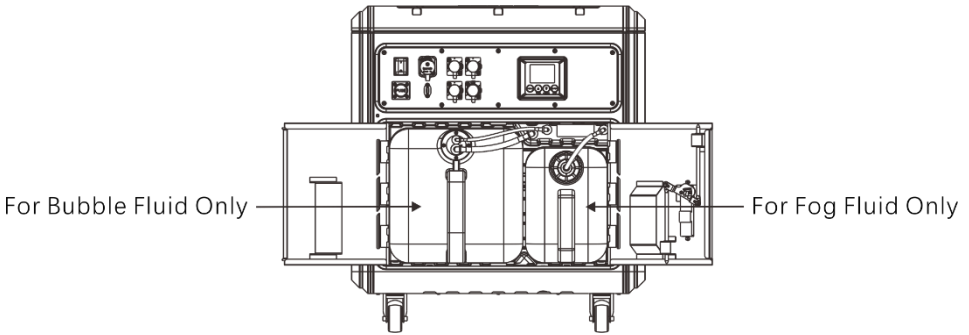

4.5.2 Rigging

Using the following general guidelines when mounting this product:

- Before deciding on a location for the product, make sure there is easy access to the product for maintenance and programming purposes.
- Make sure that the structure or surface onto which you are mounting the product can support the product's weight (see the Technical Specifications).
- When mounting the product on the floor, make sure that the product and cables are away from people and vehicles.
- When the machine is used for hanging, an optional lifting bracket is required (extra charge).
- When using the machine for hanging, first remove the machine casters, install the hanging bracket and fix the machine with M6 screws (four at the bottom, two on each side).
- The top light hook hole is $\phi 13\text{mm}$. Please choose a light hook of appropriate size and secure it firmly to a truss that can support the weight of the machine. (As shown below)

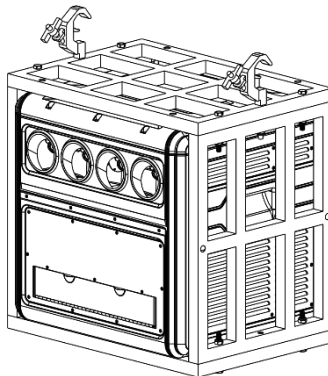

5 OPERATION

5.1 Preparing for Operation

Before operating the machine, please follow the following steps to prepare:

- After checking that all the parts are intact and complete, position the machine on flat.
- Withdraw the fluid tank from its compartment and remove its cap. Add bubble fluid and fog fluid to the specified tank.
- Verify that the plastic hoses attached to the cap are in place and in good condition without bending or warp.
- Always connect the product to a grounded circuit. Before power on, make sure it is connected with the rated voltage.
- Turn on the machine, and a color startup page will show on the display.

5.2 On-device Control Mode & Operation

The conditions for meeting this method are: disconnect the DMX signal (when the DMX signal is connected, the LCD control mode is invalid and only the DMX address code can be set).

When operating the control panel, use the four buttons below the LCD display.

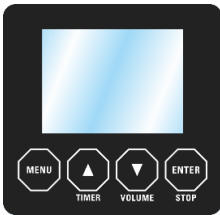





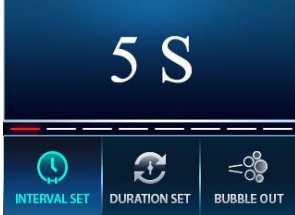

Button	Function
<MENU>	Switch menu pages to select a function
<▲>	Increases the numeric value of current function Trigger TMER output mode
<▼>	Decreases the numeric value of current function Trigger Manual output mode
<ENTER>	Save settings STOP turns the fog output off

5.2.1 Menu Map

Press the <MENU> key on the LCD control panel to switch menus. The selected menu displays green, as follows:

Display	Description	Adjustment range
	Interval time settings Press ▲ and ▼ button to set interval under TIMER mode.	5-200S

	<p>Duration settings</p> <p>Press ▲ and ▼ button to set duration under 5-200S TIMER mode.</p>
	<p>Bubble output switch settings</p> <p>Press ▲ and ▼ button to turn bubble output on or off. On/Off</p>
	<p>Output volume settings</p> <p>Press ▲ and ▼ button to set the haze output volume. 0%-100%</p>
	<p>Fan speed settings</p> <p>Press ▲ and ▼ button to set fan speed. 0-10</p>
	<p>DMX address settings</p> <p>Press ▲ and ▼ button to set DMX starting address. 1-509</p>
	<p>RDM-UID settings</p>

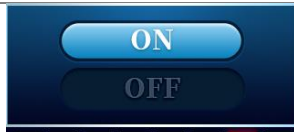

Auto run last settings

After the machine is powered off and restarted, it will remember the last running status of the machine.

On/Off

Press ▲ and ▼ button to turn on or off the function.



Cleaning mode settings

When the cleaning mode is set to on, the machine enters automatic cleaning mode, maximum cleaning time is 54 minutes.

On/Off

Press ▲ and ▼ button to turn the cleaning mode on or off.



Screen display settings

If the screen display is set to off, the screen will enter the screen-off state after 30 seconds of no operation. At the same time, the liquid level window lighting will also enter the off-state.

Press any button to wake it up.

When the screen display is set to on, the screen will remain on. The liquid level window lighting will automatically turn off after one minute of no operation. Press any button and the liquid level window lighting will light up.

On/Off

Press ▲ and ▼ button to turn on or off the screen display function.



Press <ENTER> on any page to exit/return to the first page.

Press <ENTER> in working status to stop working and return to the first page.

After entering the relevant page, press "▲" and "▼" to change the current settings.

Timer page & function

Press the <TIMER> key on the first page to enter the timing function. The relevant instructions are as follows:



On this page, you can modify parameters by pressing <MENU>. The selected content will be highlighted in red, and you can change the current settings by pressing "▲" and "▼" button.

The interval and duration will be highlighted in yellow, and the cycle countdown will automatically switch. The machine will not work during the interval, but will work according to the set parameters during the duration. .

Press the <VOLUME> key on the first page to enter the working status. The relevant instructions are as follows:



On this page, you can modify parameters by pressing <MENU>. The selected content will be highlighted in red, and you can change the current settings by pressing "▲" and "▼" button.

5.3 DMX Mode & Operation

HW-IP4 Smobble works with a DMX controller.

After the machine is connected to the DMX signal, the LCD screen can only display the DMX512 address setting page. At this time, you can set and modify the DMX512 address code by pressing the "▲" or "▼" button.

Machine has 4 DMX channels: as below

DMX Function	Channel 1	Bubble Output	0-127	OFF
			128-255	ON
	Channel 2	Haze Output	0-10	OFF
			11-255	Haze volume, low to high
	Channel 3	Wind Speed	0-23	OFF
			24-46	1st
			47-69	2nd
			70-92	3rd
			93-115	4th
			116-138	5th
			139-161	6th
			162-184	7th
			195-207	8th
			208-230	9th
	231-255	10th		
	Channel 4	Cleaning Mode	0-127	OFF
128-255			ON	

5.4 RDM Function

- "RDM-UID" is the unique UID code of the machine.
- Can use RDM to remotely modify the DMX address code.

6 TECHNICAL INFORMATION

6.1 Maintenance

After each time use of the bubble fog machine, it is necessary to clean the fog head with clean water in time to prevent the residual bubble liquid on the fog head from solidifying and gluing, which will cause it to fail to be used normally next time!

HW-IP4 requires regular cleaning and maintenance to achieve the best performance. Some cleaning and maintenance steps are essential. Here are the recommended steps for cleaning:

- 1) Unplug the product from power.
- 2) Empty bubble & haze fluid from the machine.
- 3) Add water to the bubble fluid tank.
- 4) Connect the product to power and allow it to warm up. Turn on the cleaning mode, and the machine will automatically pump clean water into the machine to clean the bubble output nozzles and tubes.
- 5) Run the product in a well -ventilated area. Do not allow the pump to run dry!
- 6) Add bubble fog and haze fluid again to continue using HW-IP4. Run the machine briefly to clear the remaining water from the pump and heater.
- 7) Excessive dust, fluid residue and dirt will degrade performance and cause overheating. Remove dust from air vents with air compressor, vacuum or soft brush. The casing could be cleaned by the damp cloth.

If the cleaning mode is not turned off manually, the machine will automatically turn off the cleaning function after the maximum cleaning time is 54 minutes.



Test-run your TOPCAT®HW-IP4 on a monthly basis to achieve the best performance.

6.2 Storage

6.2.1 Machine Storage

Before storing the machine, clean it and empty the fluid tank.

