

# **djv**

by DJPOWER

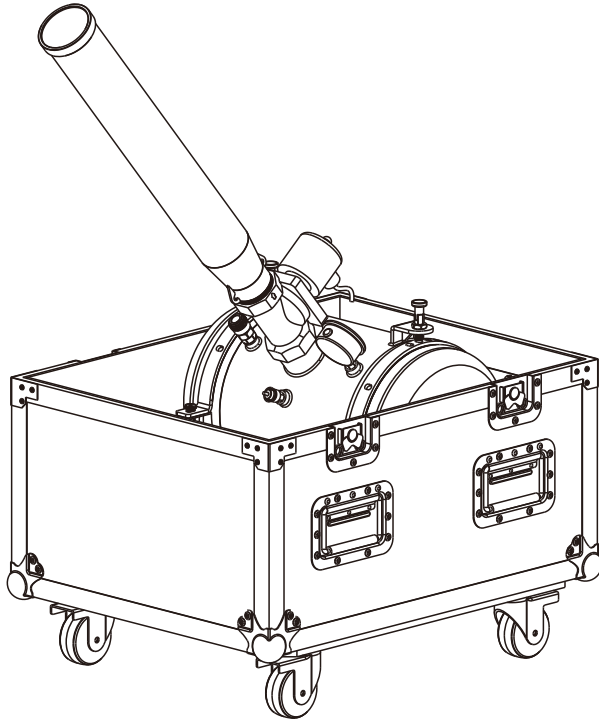

**DC-3L USER MANUAL**

---

**CONFETTI SHOT**

GUANGZHOU DJPOWER ELECTRONIC TECHNOLOGY CO.,LTD

# 1 BEFORE YOU BEGIN

## 1.1 Package Content



DC-3L Confetti Shot / Water Cannon Barrel × 1    Pressure Reducing Valve × 1    Power Cord × 1  
2-meter PU Tube × 1    User Manual × 1    Warranty Card × 1    Certification × 1

**Optional: Water Cannon Barrel & Automatic Water Supply System (extra charge).**

## 1.2 Unpacking Instructions

If the box or the contents (the product and included accessories) appear damaged from shipping, or show signs of mishandling, notify the carrier or dealer / seller immediately. In addition, keep the box and contents for inspection.

## 1.3 Symbols

Symbol	Meaning
<i>Caution</i>	
	Critical installation, configuration and operation instructions. Failure to follow these instructions may result in product malfunction or personal injury.
<i>Important</i>	
	Important installation or configuration information. Failure to comply with the instructions may lead to product malfunction.
<i>Information</i>	
	Useful information.

## 1.4 Disclaimer

The information and specifications contained in this User Manual are subject to change without notice. DJPOWER assumes no responsibility or liability for any errors or omissions and reserves the right to revise this manual at any time.

Copyright © 2025 DJPOWER. All rights reserved.

## 1.5 Safety Notes

Please read the following Safety Notes carefully before operating the machine. The notes include important safety information about installation, usage, and maintenance.

### 1.5.1 Carbon Dioxide (CO<sub>2</sub>)

DC-3L can use liquid carbon dioxide. Improper use of CO<sub>2</sub> may result in serious consequences. Before installation or operation, make sure you are aware of the hazards of improper use. Please use certified carbon dioxide cylinders, tubes and connectors, and consult your local supplier for rules and instructions for safe installation and use.

DJPOWER assumes no responsibility or liability for the dangers, accidents and damages caused by improper use of carbon dioxide and the gas cylinders.



**Improper installation or operation of carbon dioxide machines and cylinders may cause serious injury or death. Please operate according to the instructions of the user manual, or the instructions of the supplier, or your local authorized person.**

### 1.5.2 Personal Safety

- Always connect the product to a grounded circuit to avoid the risk of electrocution.
- Never point the nozzle at people or animals.
- Make sure that children, unauthorized people and animals do not obtain access to the machine.
- Ensure no loose objects or obstacles are present within the nozzle's output path to prevent injury. Maintain a 20-25 meter safety distance between personnel and the machine's operational zone.
- Always establish a 5-meter radius safety perimeter around the equipment. Keep unauthorized people, animals, and objects away from this zone at all times.

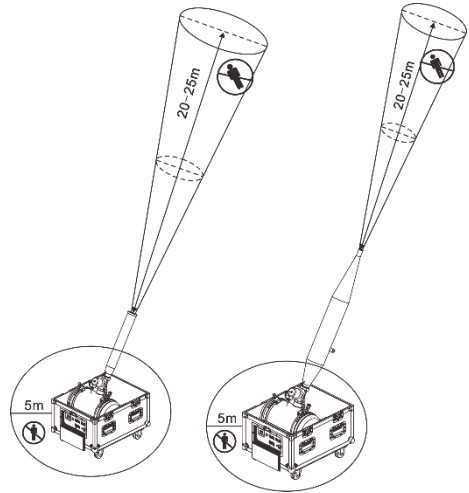

### 1.5.3 Mounting and Rigging

- For safety reasons, we do not recommend other installation methods. Please operate the machine on a flat ground and lock all four casters.
- Do not place the product near a vibration source.
- When relocating the machine between extreme temperature environments (e.g., cold / dry to warm / humid), always allow it to acclimate to ambient conditions before power connection to prevent condensation-induced electrical hazards and ensure no flammable materials are nearby during operation.
- Never install the machine on a flammable surface (e.g., linoleum, carpet, wood, paper, carton, plastic, etc.).
- Always operate the machine in the well-ventilated area.
- Check the pressure level on the gauge before each transport. Open the vent valve to reduce internal air pressure if necessary.
- Do not transport the machine while the system is pressurized.
- To move a pressurized machine, you MUST power it off and disconnect all cables before relocation - failure to do so may cause critical safety hazards.
- If the machine exhibits abnormal behavior during operation (e.g., low-height confetti bursts or weak water cannon projection), follow these steps: open the tank assembly, loosen the pressure reducing valve and drain all residual water from the tank.

### 1.5.4 Power and Wiring

- Always connect the machine to the correct rated voltage.
- Make sure the power cord is not crimped or damaged.
- Never connect this product to a dimmer pack or rheostat.
- Never disconnect the product from the power cord by pulling or tugging on the cord.
- To avoid unnecessary energy consumption and extend the machine's service life, completely disconnect the product from power by either switching off the circuit breaker or unplugging the power cord when not in use.

### 1.5.5 Operation

- Do not operate the product if any damage is observed to the machine housing or cables. Immediately contact authorized technician to replace damaged components.
- Do not cover or plug the output nozzle during operation.
- Never carry the product by the power cord or any moving part. Always use the handles.
- Please keep a certain distance from the machine to avoid injury.
- This product contains no user-serviceable parts. Any reference to servicing in this User Manual will only apply to properly trained and certified technicians. Unauthorized disassembly or modification may cause damage or malfunction.
- If a serious malfunction occurs during operation, stop using it immediately.
- Ensure that the machine is operated in a well-lit environment.
- DO NOT remove any safeguards, safety caps and safety symbols.



**Please note that confetti may stain surfaces when landing on wet or damp floors, making cleanup difficult. Use only in dry, non-sensitive areas. We assume no liability for damage resulting from failure to comply with this and other safety requirements.**



**Keep this User Manual for future use. If you sell the product, please be sure that the purchaser receives this document.**

## 2 INTRODUCTION

### 2.1 Description

DC-3L is an inflatable confetti shot / water cannon machine newly launched by DJPOWER. It is designed with an integrated flight case, sturdy and durable tank structure. Powered by compressed air or liquid CO<sub>2</sub>, it instantly launches the confetti or streamer into the air up to a height of 30 meters. It is perfect for large celebrations, concerts, stadiums and festivals.

### 2.2 Product Features

- Dual-functional design: optional confetti cannon or water cannon to meet the needs of different scenes;

- Large pressure tank with 20L capacity, sturdy and durable;
- Excellent workmanship, safe and reliable;
- Adjustable spraying angle with maximum vertical range of 30m;
- Integrated-designed with flight case enables rapid disassembly / assembly, convenient for transport;
- An optional water cannon barrel is available to meet the needs of different scenarios.

**Note: The actual effect may be affected by the operational conditions.**

### 2.3 Appearance Overview

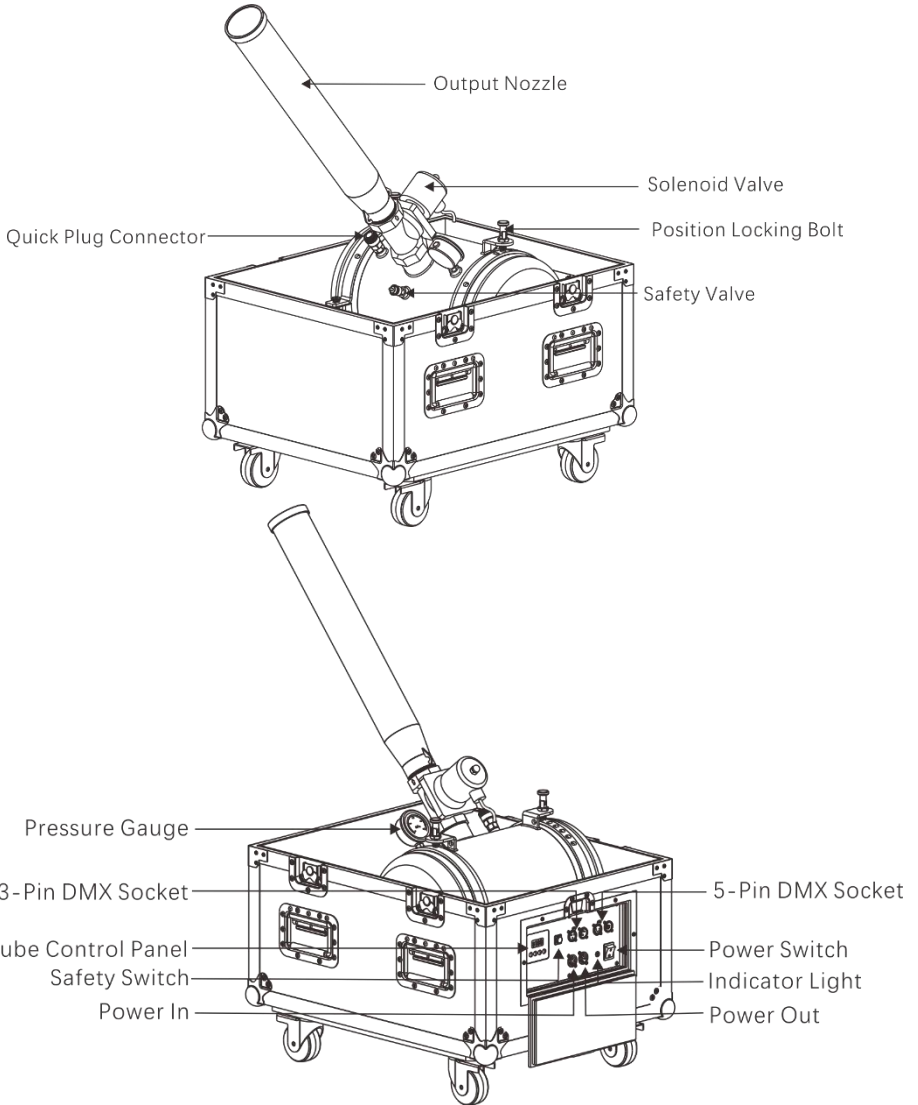

## 2.4 Product Dimensions

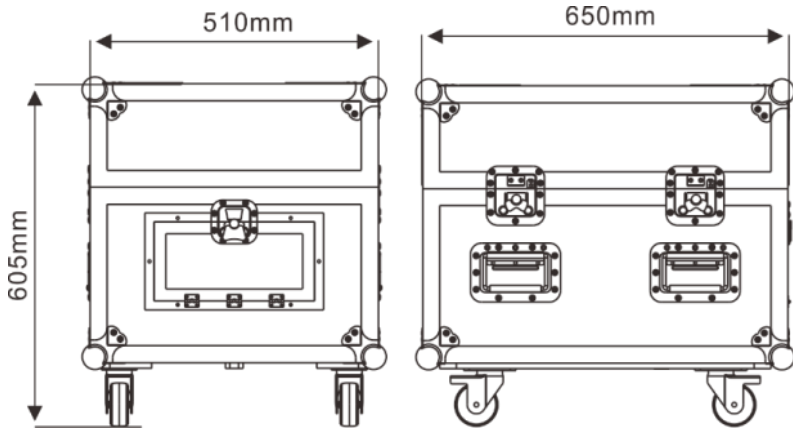

Optional: Water Cannon Barrel (extra request upon order)

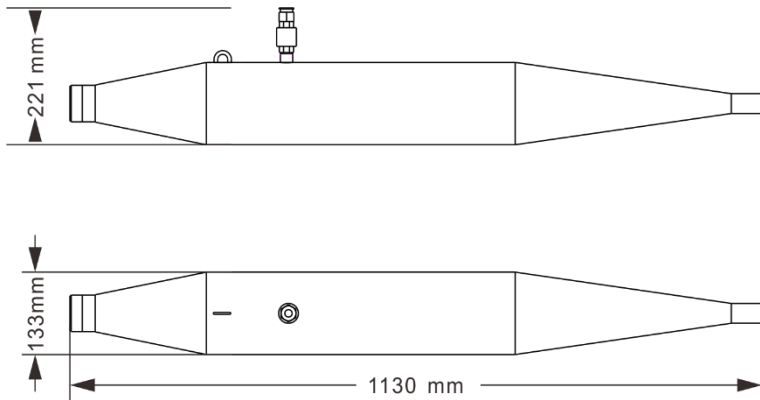

## 3 TECHNICAL SPECIFICATIONS

	<b>Input Voltage &amp; Rate</b>	<b>AC 100V-240V 50/60HZ</b>
<b>AC Power</b>	Total Power Consumption	50 W
	Power Input Connector	Lockable PowerCon
	Power Output Connector	Lockable PowerCon
<b>Output</b>	Max Output Height	Appr. 30 meters
<b>Control</b>	On-device Manual Control	Digital Tube Control Panel
	Wireless Control	×

	Wired Control	×
	Control Protocol	DMX-512
	DMX Channel Range	2
<b>Capacity</b>	Confetti Shot Barrel Capacity	2.5 L
	Water Cannon Barrel Capacity	10 L
	Gas Tank Capacity	20 L
<b>Consumable</b>	Consumable	Liquid Carbon Dioxide, Confetti and Streamer
<b>Weight &amp; Dimensions</b>	Net Weight	51 kg
	Gross Weight	52.5 kg
	Machine Dimensions	650 × 510 × 605 mm
	Packing Dimensions	692 × 557 × 520 mm
<b>Water cannon barrel optional accessory (individually packaged)</b>	Net Weight of Water Cannon Barrel	5.6 kg
	Gross Weight of Water Cannon Barrel	7.4 kg
	Water Cannon Barrel Dimensions	1130 × 133 × 221 mm
	Water Cannon Barrel Packing Dimensions	1250 × 274 × 197 mm
<b>Automatic water supply system accessory (individually packaged)</b>	Input Voltage & Rate	AC 100V-240V 50/60HZ
	Insurance	2 A/250V
	Total Power	10 W
	Net Weight	2.8 kg
	Gross Weight	4.5 kg
	Accessory Dimensions	235 × 83 × 286.5 mm
	Packing Dimensions	456 × 280 × 123 mm

## 4 SETUP

### 4.1 AC Power

The machine has a fixed voltage power supply and can work with an input voltage of AC 100V-240V 50/60HZ.

To determine the machine's power requirements (circuit breaker, power outlet, and wiring), use the current value listed on the label affixed to the machine's back panel, or refer to the machine's specifications chart. The listed current rating indicates the machine's average current draw under normal conditions.



**Always connect the machine to a protected electrical circuit (circuit breaker or fuse). Make sure the machine is connected to a grounded power plug to avoid electric shock or fire.**



**Never connect the product to a rheostat (variable resistor) or dimmer circuit, even if the rheostat or dimmer channel serves only as a 0 to 100% switch.**

## 4.2 AC Plug

The machine comes with a power cord with a lockable Powercon on one end and an EU plug on the other. If the power cord that came with your product has no plug, or if you need to change the plug, use the table below to wire the new plug:

	Wire (China)	Wire (Europe)	Wire (U.S.)
<b>AC Live</b>	Brown	Black	Brown
<b>AC Neutral</b>	Blue	Blue	White
<b>AC Ground</b>	Green	Green / Yellow	Green

## 4.3 DMX Connection

You can link the DC-3L to a DMX controller using a 3-pin or 5-pin DMX connection. If using other DMX-compatible products with this product, you can control each individually with a single DMX controller. Instructions for connecting and configuring this product for DMX operation are in the User Manual.

## 4.4 Mounting

Before mounting the product, read and follow the safety recommendations indicated in the Safety Notes.

### 4.4.1 Rigging

DJPOWER recommends using the following general guidelines when mounting this product.

- Make sure that the structure or surface onto which you are mounting the product can support the product's weight (see the Technical Specifications). Square the casters outward to lock the pulleys.
- Align the threads of the barrel (or water cannon barrel) with the solenoid valve threads. Gently rotate counterclockwise to locate the thread starting point, then clockwise to tighten until the barrel is fully secured.
- After connecting the water cannon to the water supply, pressurize and test for leaks at the connection. Re-installation is required if there is leakage.



**Make sure the water cannon barrel is fully filled before operation. Stop operation when the water is insufficient to prevent equipment damage and personal injury.**

### 1. Installation Diagram of Confetti Shot Barrel

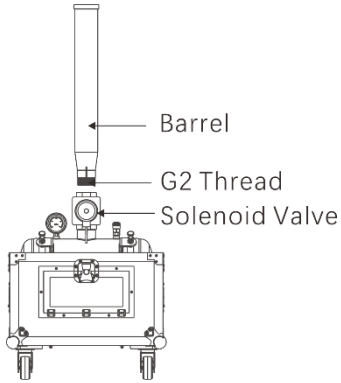

## 2. Installation Diagram of Water Cannon Barrel

Note: 1. During operation of water cannon, a slight backward phenomenon is a normal phenomenon due to recoil force, to ensure safe operation, do the following precautions.

Install safety rope to secure the water cannon barrels and also on the handles on both sides of the flight case. A rain cover is required for outdoor use in rainy weather.

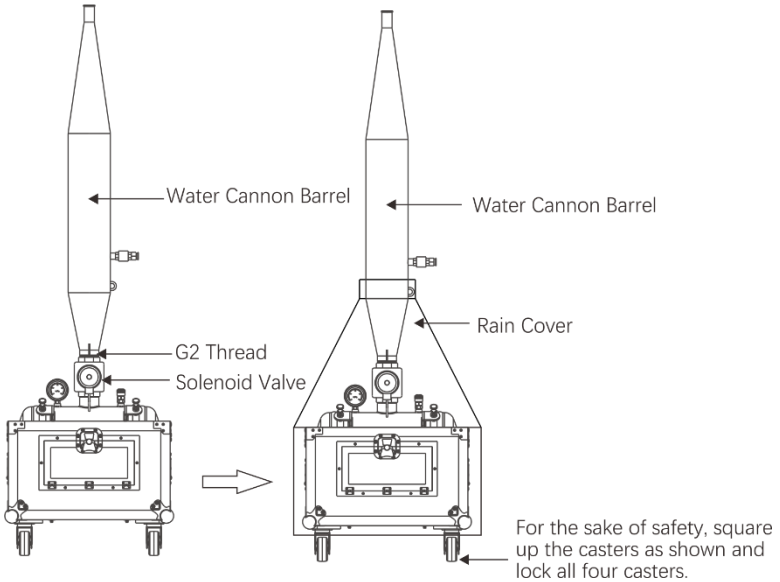

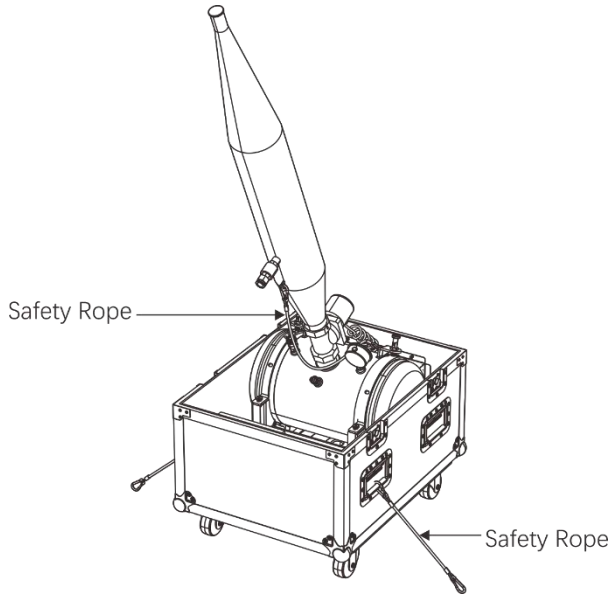

#### 4.4.2 Gas Tank Angle Adjustment Operation Guide

##### 1. Safety Preparation

- Close the gas tank valve to ensure gas supply is stopped.
- Keep the operating environment ventilated and away from open flames or electric sparks.

##### 2. Pull up the position locking bolt.

##### 3. Adjusting the Angle.

- Hold the gas tank with both hands and slowly rotate it to the desired direction. It supports 7-angle adjustment.
- Ensure that the bottom of the gas tank stays close to the base to avoid overhang.

- ##### 4. Turn the bolt until it can fit into the lower slot and you will hear a "click". The bolt is successfully locked when it can't turn anymore.

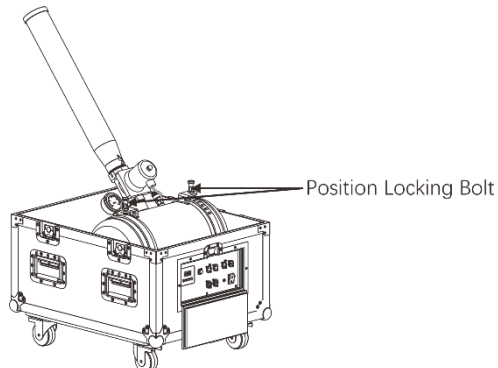

# 5 OPERATION

## 5.1 Preparing for Operation

- Connect the nozzle: put the nozzle on the female connector and lock it firmly;
- Adjust the nozzle angle;
- Put the confetti or streamer into the nozzle;
- Use a outsourced pressure pump or air compressor to pressurize the tank to 0.8MPA, not more than 0.8MPA;
- Plug the power cord into a grounded socket. Before turning on the power, please check the voltage again.

## 5.2 On-device Control Panel

This machine has DMX control, manual control, and power-on control output functions. DMX control has the highest priority in any control mode.

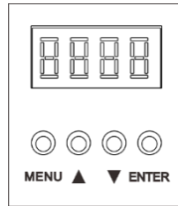

Button	Function
<MENU>	Realize the cyclic conversion of the digital display main page. Press the button to change a display page. DC-3L has two setting pages
▲	Up-adjusting settings of sub-page parameters under each display page
▼	Down-adjusting settings of sub-page parameters under each display page
<ENTER>	After selecting the page, enter the sub-page or exit the sub-page

Note: The machine operation panel has a safety lockable button and a safety indicator light.

### 5.2.1 Menu Map

	Display	Description	Parameter Range
Setting Page		On this page, press ENTER to enter the DMX address setting page. Press "▲" and "▼" to adjust the DMX address, and press ENTER to return to the previous page after confirmation. After setting the DMX address, you can connect the DMX signal to control the device.	

Setting  
Page



On this page, press ENTER to enter the setting menu, and press the "▲" and "▼" to set on or off. This setting can be used as a function of manual operation of the machine. When it is set to on, the machine will work if the safety self-locking button is pressed. When it is set to OFF, the machine stops working. If the safety lock is not pressed, the machine will not work.

ON / OFF

In addition, if it is set to the on state, the next time the machine is powered on, it can work directly, and the response time from power on to the machine working is less than or equal to 0.5S.

### 5.3 Manual Control Mode

When the digital tube display is set  to ON and the safety lock on the operation panel is pressed simultaneously, the machine will begin to work. When set to OFF, the machine stops working. If the safety lock is not pressed, the machine will not work.

### 5.4 Safety Lock and Safety Indicator Light Function

- **Safety lock button not pressed**

The safety indicator light is off, indicating the machine is not started.

- **Safety lock button pressed**

The safety indicator light flashes, indicating the machine is in standby mode.

- **Safety lock pressed and spray triggered**

The safety indicator light is always on and the machine is spraying confetti.

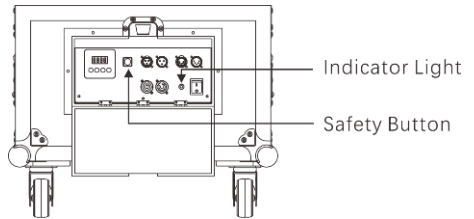

### 5.5 Power-On Operation Function

When the device is not controlled by DMX, and the digital tube display is set  to ON and the safety lock is pressed simultaneously, the machine will trigger the power-on automatic spraying function, which will work as soon as the machine is powered on.

### 5.6 DMX Mode & Operation

DC-3L can work with a DMX controller:

- Connect the machine to a suitable electrical outlet.
- Connect the DMX output of the DMX controller to the DMX input socket on the machine via a DMX cable.

- Turn the power switch upwards, and you can control the machine by DMX controller.

When the DMX signal is connected, only the address code will be showed on the display page of the digital tube. In addition, the safety channel must be set in the ON state for the output channel to control machine operation.



When the safety channel is opened, the indicator light on the machine operation panel will flash, indicating that the machine is ready to work.

When the safety channel is closed, the indicator light is off.

When the safety channel is opened and the machine is triggered to spray, the indicator light is always on.

This machine supports 2 DMX channels. The channel table is as follows:

Channel	Function	Value	Description
1	Safety Channel	0-99	OFF
		100-155	ON
		156-255	OFF
2	Output Channel	0-10	OFF
		11-255	ON

## 5.7 Automatic Water Supply System (Optional Accessory) Installation & Operation

The DC-3L water cannon can be equipped with an optional automatic water supply system for auto replenishment. It supports multi-device series connection: electrical via power input/output sockets, and water via inlet/outlet ports. A filter cartridge is recommended at the main water inlet. Before filling, ensure the air tank pressure is at least 0.1 MPa and the water supply pressure is at least 0.1 MPa. The outlet connects to the water cannon barrel via a hose.

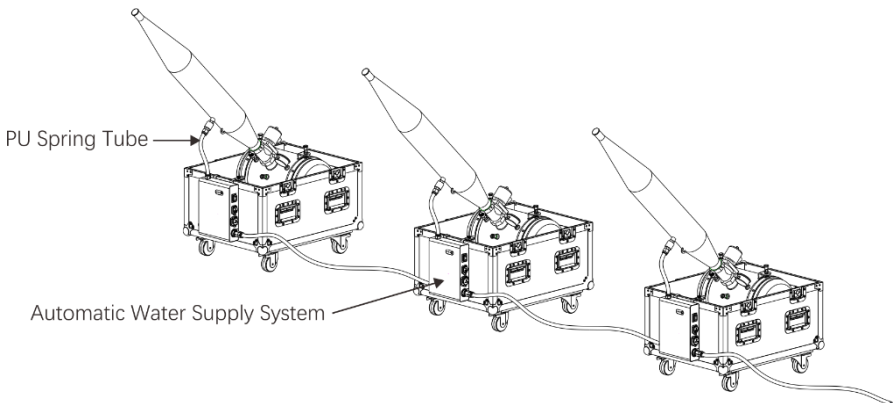

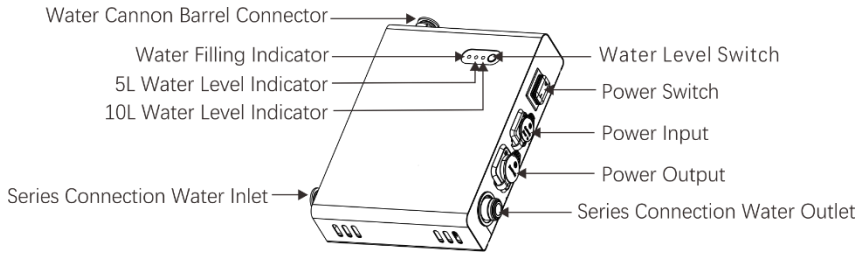

### 5.7.1 Water Filling Indicator

Flashing	Filling Water
Always On	Water Volume Reaches the Set Value
Always Off	Water Filling Off

## 6 TECHNICAL INFORMATION

### 6.1 Maintenance

- To achieve the maximum service life of the machine, you must regularly clean the machine and test if it is functioning correctly.



**Do not replace parts by yourself, consult DJPOWER if necessary.**

### 6.2 Storage

Store the machine in a dry and cool place.



