

HF-210S  **FLAME
MACHINE**

USER MANUAL

GUANGZHOU DJPOWER ELECTRONIC TECHNOLOGY CO.,LTD

1. BEFORE YOU BEGIN

1.1. What Is Included

Flame Machine (newly upgraded) × 1

User Manual × 1

Flight Case × 1

Warranty Card × 1



Power Cord × 1

1.2. Unpacking Instructions

Carefully unpack the product immediately and check the container to make sure all the parts are in the package and are in good condition.

If the box or the contents (the product and included accessories) appear damaged from shipping, or show signs of mishandling, notify the carrier or dealer/seller immediately. In addition, keep the box and contents for inspection.

1.3. Symbols

Symbol	Meaning
	Caution Critical installation, configuration, or operation information. Not following these instructions may make the product not work, cause damage to the product, or cause harm to the operator.
	Important Important installation or configuration information. Failure to comply with this information may keep the product from working correctly.
	Information Useful information.

1.4. Disclaimer

Thanks for choosing DJPOWER Flame Machine HF-210S. When you purchase this machine, you will recognize the following instructions by default. Please read following manual carefully and completely before operating this product. Operate according to instructions is very important for safety, and can elongate the service life of the machine. Strictly follow the instruction in the manual when operate flame machine HF-210S. If you have any doubts, please contact DJPOWER.

Use the HF-210S only under the rules and instructions from this manual. Contact DJPOWER in case of doubts about the usage.

We assume that you, your employees and others who use or come in contact with the machine are familiar with how the machine should be handled. This includes proper use, maintenance and repair of the machine as defined in this user guide. This also means that employees are familiar with the use of machinery through training or experience.

DJPOWER excludes liability for unsafe situations, accidents and damages resulting from:

1. The machine is not arranged for use by professionals, and the machine is still used when the machine malfunctions or is damaged.

2. The Flame Fluid Can was not emptied before the machine was shipped.
3. Ignoring warnings or regulations as shown on Wave flame machine or this manual.
4. Use for other applications or circumstances other than those indicated herein.
5. Use this machine by unqualified or untrained personnel. including use of non-original spare parts.
6. Removed safety cover without authorization from DJPOWER.

DJPOWER is not liable for the damages caused by failure of the wave flame machine.

The information and specifications contained in this manual are subject to change without notice and keep the right to modify or revise this manual at any time. Copyright© 2022 DJPOWER All rights reserved.

1.5. Safety Notes

Please read the following Safety Notes carefully before working with the product. The notes include important safety information about installation, usage, and maintenance.

1.5.1. Personal Safety

- Make sure that children, unauthorized people and animals do not obtain access to the machine.
- After the machine is turned on, it is strictly forbidden to stay in the dangerous area of the machine. Safety distances for HF-210S: At least 15m in all projection directions, at least 5m to the other sides of the device.
- Please prepare dry powder and fire extinguishing equipment at the machine use place. Always have a dry powder fire extinguisher, CO2 fire extinguisher, and an extinguishing blanket in case of needed.

1.5.2. Mounting and Rigging

- CAUTION: When transferring product from extreme temperature environments, (e.g. cold truck to warm humid ballroom) condensation may form on the internal electronics of the product. To avoid causing a failure, allow product to fully acclimate to the surrounding environment before connecting it to power.
- Do not mount the product on a flammable surface (linoleum, carpet, wood, paper, carton, plastic, etc.). Keep a safe distance from the unit, the unit can only be placed horizontally.

1.5.3. Power and Wiring

- Please use a grounded socket to avoid the risk of electric shock.
- Make sure power supply in consistent with the rated voltage of the equipment, Unplug and turn off the machine when not use.
- Check that the power cord is not pinched or damaged.
- Do not connect the machine to a dimming controller or varistor.
- Do not disconnect the power supply by pulling the power cord.

1.5.4. Operation

- The maximum ambient temperature is 40 ° C. Do not operate the machine in a high temperature environment.
- Do not operate this product if the machine casing or cable is damaged. Immediately ask the authorized technician to replace the damaged part.

- Make sure there are no flammable materials around the machine before operation, and keep a safe distance between the person and the equipment. The Safe distance for the HF-210S is: at least 15m in all projection directions, at least 5m to the other sides of the device.
- Before connect the power cable, communication DMX cable should well connected and ensure the command keep at firing OFF status. And safety lock stay at test mode.
- The operator responsible for the control of Wave flame machine must always have a clear view of the device, so that he/she can stop the show immediately when there is danger. The main AC power switch should near operator. So that operator can turn off the power of all devices in case of abnormal.
- If there be any doubt as to the safety operation of the device in any circumstances, the device should be taken out of service immediately. Be sure the device is in good operating condition before use, check the sparkle oil, fuse, cable and power plug. If fail to fire correctly, immediately shut down and contact the factory.
- **Empty the Flame Fluid Can before transporting the machine.**
- The machine does not contain any user disassembled and self-repaired or modified parts. Do not attempt to repair or modify the machine yourself without any training or authorized technicians to avoid damage or malfunction.
- Notes for use of Battery power supply: Wave flame machine HF-210S with stable internal circuit design, please support the unit with battery voltage higher than 12V. The driving speed of motor won't change because of the decrease of battery power supply. Battery options: 12V lead-acid battery (above 30AH, with more than 24h standby). For Lithium battery, please use battery with output above 30A. 4 pin sound couplers (1+ connect 12V anode, 1- connect 12V cathode). Connecting power cables should above 14AWG.
- Be sure to use the suitable flame fuel indicated in the user manual, otherwise, it is easily lead to failure or danger. Do not add any material other than the specified proportion of castor oil in the oil drum. Be careful when refill the flame fluid tank. Please keep flame fluid away from heat source, sparks, fire or other possibility of ignition.



It is strictly forbidden to use water or other liquids instead of special consumables, otherwise it will cause serious failure.



Please save this manual for future use. Sell the machine again, be sure to attach the instructions.

2. INTRODUCTION

2.1. Description

HF-210S is DJPOWER's newly upgraded wave flame machine. It is equipped with dual ignition and rainproof structure design. With a maximum rotation angle of 210° and flame effect reaches up to 8m. The dual valve and dual pump design is safe and reliable. It is preset with 85 sequences of flame effects, for which can be controlled by DMX to get fire-breathing effects, such as multi-angles burst, left and right burst, swing flame etc. It is suitable for all kinds of shows to create excellent atmosphere.

2.2. Features

- Dual ignition ensures successful ignition;

- Rainproof structure design, IPX3 waterproof grade;
- The dual valve and dual pump design , safer and more stable;
- The maximum rotation angle is optional: ground mode: 180° (±90°) or suspended (5 meters and above) mode: 210° (±105°);
- Fast and precise flame burst;
- With tilt sensor design, output is auto off when tilts to 45°in any direction;
- Unique safety lock to avoid false triggering;
- Thicken and anti-rust metal structure, durable in use;
- Intelligent electronic control system with pressure monitoring, safety alerts, and fault alarms ;
- Built-in LCD control, 3-pin and 5-pin DMX control;
- Full set of SEETRONIC rainproof power connectors;
- With battery interface, support external 12V battery supply.

Note: The actual effect may be affected by the use environment.

2.3. Product Overview

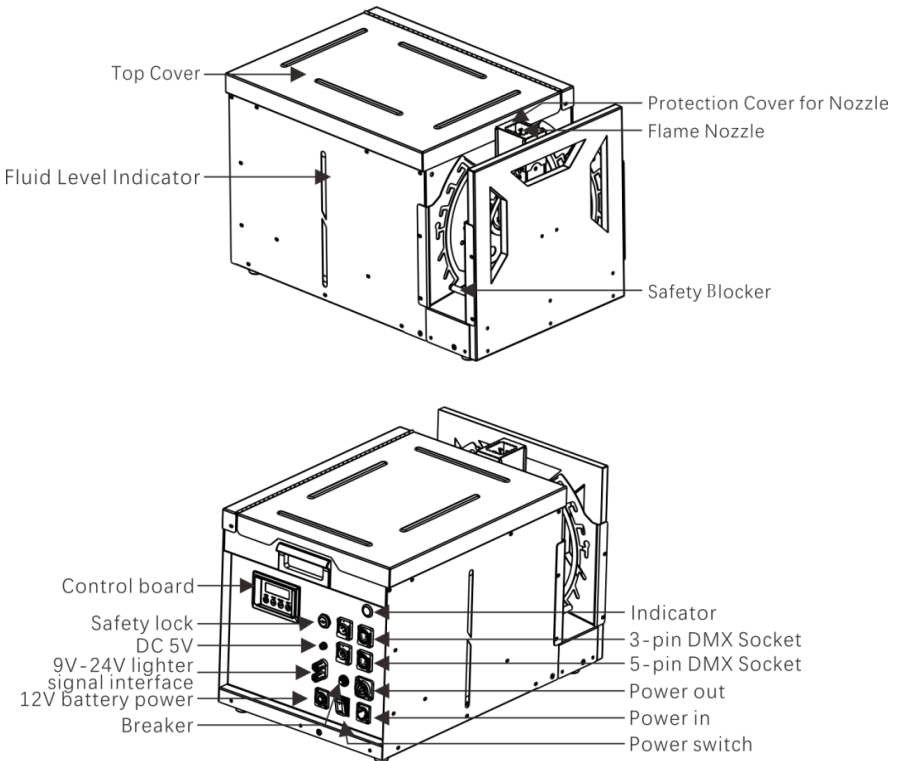

2.4. Product Dimensions

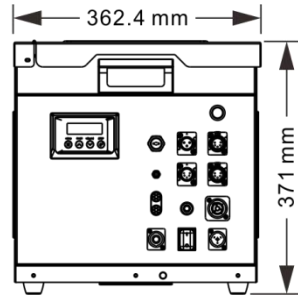
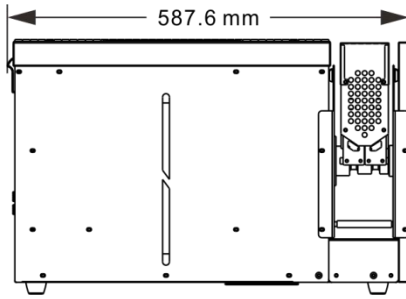

2.5. Flight Case Dimensions

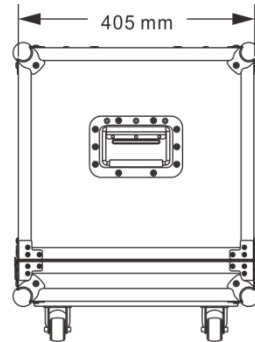
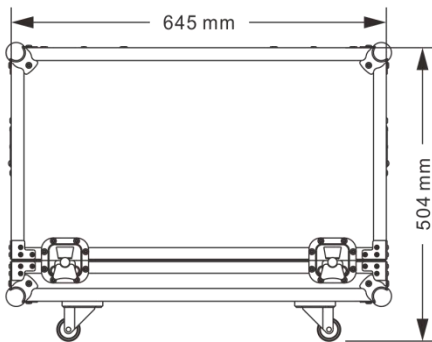

3. TECHNICAL SPECIFICATIONS

Voltage	AC 100-120V,50/60 Hz	AC 200-240 V, 50/60 Hz
Breaker	8 A, 250 V	
Current limiting insurance type	Breaker	
Power	600 W	
Tank Capacity	10 L	
Horizontal placement	√	
Tilt	×	
Side placement	×	
Up-side-Down	×	
Hang	×	
Body Control	LCD control panel	
Wireless Control	×	
Wire Control	√	
Maximum Output Height	Appr. 8-10 meters(no wind condition)	
Maximum effect Angle (Optional)	ground mode: 180° (±90°)	

Maximum effect Angle (Optional)	suspended (5 meters and above) mode: 210° (±105°)
Fluid Consumption Rate	Appr. 0.48 min/L
DMX address	6
Consumable	ISOPAR-G (isopropanol or bio-ethanol is optional only under special request, please consult sales manager first. In order to protect the fuel pump and pipeline, 10-20ml of hemp oil must be added to every 10L of fuel, otherwise the fuel pump and components will be damaged)
Machine Net Weight(with flight case)	45.7 kg
Gross Weight	48.4 kg
Machine Dimensions	587.6 × 362.4 × 371 mm
Flight case Dimensions	645 × 405 × 504 mm
Packing Dimensions	720 × 480 × 570 mm

4. SETUP

4.1. AC Power

The machine has two kinds of voltage power supply, it can work with an input voltage of AC 100 V-120 V, 50/60 Hz or AC 200 V-240 V, 50/60 Hz, depending on the specific model.

To determine the product's power requirements (circuit breaker, power outlet, and wiring), use the current value listed on the label affixed to the product's back panel, or refer to the product's specifications chart. The listed current rating indicates the product's average current draw under normal conditions.



Always connect the product to a protected circuit (circuit breaker or fuse). Make sure the product has an appropriate electrical ground to avoid the risk of electrocution or fire.



Never connect the product to a rheostat (variable resistor) or dimmer circuit, even if the rheostat or dimmer channel serves only as a 0 to 100% switch.

4.2. AC Plug

The Flame Machine HF-210S comes with a power input cord terminated with a Lockable Powerkon connector on one end and an EU plug on the other end (EU & China market). If the power input cord that came with your product has no plug, or if you need the change the plug, use the table below to wire the new plug:

Connection	Wire (U.S.)	Wire (Europe)
AC Live	Black	Brown
AC Neutral	White	Blue
AC Ground	Green/Yellow	Green/Yellow

4.3. Resetting the Breaker

This product is equipped with a resettable breaker. If the breaker trips, all sections of this product will lose power.

- Remove the power cord from mains power.
- Reset the breaker by pressing the button with your finger.
- Plug the product's power cord into the power outlet and continue using as recommended.

5. OPERATION

5.1. Preparing for Operation

Before operating the machine, please follow the below steps to prepare:

- Before operation, please ensure that there are no flammable materials around the machine, and people and equipment should maintain a certain safe distance. Safety distances for HF-210S: At least 15m in all projection directions, at least 5m to the other sides of the device.
- After checking that all the parts are intact and complete, position the machine on flat.
- Please connect the communication line before the power is turned on, and ensure that the communication command is non-injected and the device is in test mode.
- Always connect the product to a grounded circuit. Before power on, make sure it is connected with the rated voltage.
- The operator should near the machine and be able to directly see the status, and immediately terminate the performance when there is a danger. There should be a total AC power switch near the operator. When an abnormality occurs, the power should be disconnected in time. This is the safest way to do this.

5.2. On-device Control Panel

To access the control panel functions, use the four buttons located underneath the LCD display.

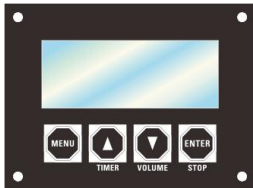

Button	Function
<MENU>	Switch menu pages to select a function
▲	Increases the numeric value of current function
▼	Decreases the numeric value of current function
<ENTER>	Switch between current menu page and Standby Page

5.3. On-device Control Mode & Operation

5.3.1. Programming

- Refer to the Menu Map to understand the menu options. The menu map shows the main level and a variable number of programming levels for each option.
- To go to the desired main level, press <MENU> repeatedly until the option shows on the display. This will take you to the first programming level for that option.
- To select an option or value within the current programming level, press <TIMER> <▲> or <VOLUME><▼> until the option shows on the display. If there is another programming level, you will see that first option, or you will see the selected value.
- Press <MENU> repeatedly to switch menu pages.

- Press <STOP> to return to the standby page.

5.3.2 Menu Map

	Display	Description	Parameter Range
Starting Page	HF-210S REV		
	Initializing... P:0 V:12	When the external trigger function is ON, showing this page	
Standby Page	Wait To Connect P:0 V:12	When the external trigger function is OFF, to connect to DMX control, showing this page	
Working Status Page	DMX address 1 P:0 V:12	Under DMX control, showing the DMX address setting	
	Ready To Work P:0 V:12	When external trigger is ON and the unit is connected to external trigger, after pressurization is completed, it shows this page	
Menu Page	DMX address 1	Setting DMX address	1~512
	Ext Ignite ON	Setting External fireworks ignitor status Please use 9-60V fireworks ignitor signal	ON/OFF
	Set ExtSequence 85	Setting Preset sequence triggered by fireworks ignitor	1~85
	Tip switch ON	Setting the tilt protection (In case it is ON, if the machine tilts over 45°, it stops the unit from firing)	ON/OFF
	WindowLight ON	Setting LED light which illuminates the fluid level indicator	ON/OFF
	Angle Selection ground mode 180	Angle selection	Horizontal placement model: 180 Hang model: 210; Left 105, Left 90, Left 75, Left 60, Left 45, Left 30, Left 15, middle 0, right 15, right 30, right 45, right 60, right 75, right 90, right 105
	language English	Language setting	

Error and Warning Page	E1: Pressure Err P:0 V: 12	Pressure failed to reach 100% after 13s pressurizing, system will report E1 Possible fault: No fuel; pump failure; pipeline problem etc	
	E2: Tip Err P:0 V: 12	The machine tilts over 45° , it stops running, system will report E6	
	E3: Bat Err P:0 V: 12	Machine stops running due to battery voltage higher than15V or lower than 10V for 5s contentiously Possible fault: the battery is low	
	E4: System Lock P:0 V: 12	Safety lock located at TEST MODE	
	E5: Relief Err P:0 V: 12	Pressure relief error due to pipeline can't release pressure Possible fault: pressure release valve failure; pipeline problem or control system problem etc	

5.4. Operation

5.4.1. Orientation

Please read the safety distance print on the top panel of the FLAMER carefully.

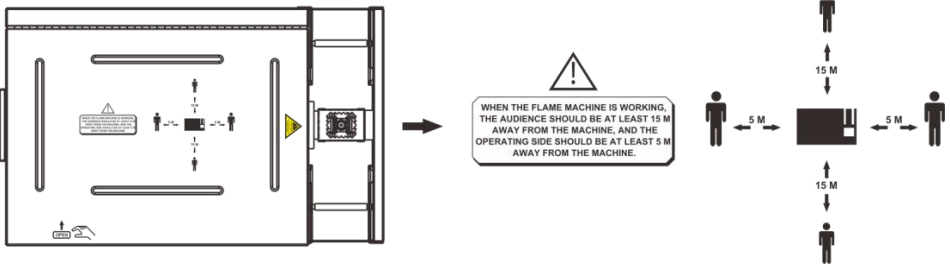

Note:

1. Safety distances for Wave flame machine are indicated in above picture. At least 15m in all projection directions, at least 5m to the other sides of the device. In order to indicate correct direction, please place the top panel correctly.
2. Open the top cover of the flamer from the "OPEN" position, take out the flame fluid can, and add the fuel.
3. The nozzle is still hot after the flamer worked, to prevent burns, do not touch, wait for natural cooling.

5.4.2. Safety Blocker

The HF-210S is designed with an Safety blocker which can be used to limit the firing angle within the safe range to prevent the machine from injecting flame in the wrong direction in case the unit is mishandled or out of control. There are 7 positions by left and right side of the nozzle with 15° apart for each position.

The maximum angle of the blocker: position ①: one side maximum angle 15°; position ②: one side maximum angle 30°; position ③: one side maximum angle 45°; position ④: one side maximum angle 60°; position ⑤: one side maximum angle 75°; position ⑥: one side maximum angle 90°; gear position ⑦: one side maximum angle 105°.

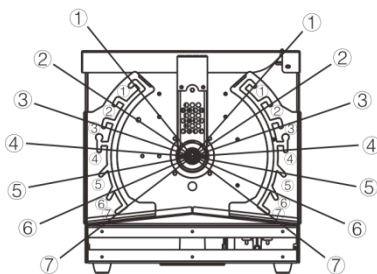
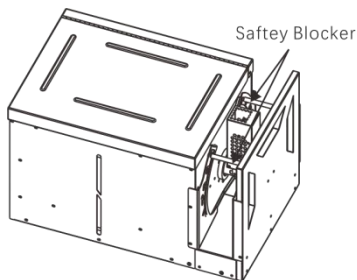

5.4.3. Quick Operation Sheet

Immediately upon receiving the machine, carefully unpack the carton, check the machine received in good condition. Ensure safety operation of machine, please do following below operation procedures when operate flame machine.

Operation step	Schematic diagram	Explanation
1	Installation	The device can only be placed horizontally, if placed on truss, please locked with extra safety cables.
2	Locate safety lock at TEST MODE	Before operate machine please locate safety lock at TEST MODE. Under TEST MODE, operator can test the rotation of nozzle, but the fuel ejection function is disabled to prevent firing. Under USER MODE: the device can run normally. Please strictly follow the safety distance requirement. Human beings, animal or flammable objects shall be away from the danger area.
3	Fueling	Take out the flame fluid can and add fuel; carefully put it back into the cabinet to avoid spilling; ensure that the tube is placed in the fluid can; tighten the container cap. Please use the designated suitable fuels.
4	Power and DMX cable connection	Two power supplies are available for selection: 1). 110V/220V main power supply; 2). 12V battery power supply.
5	Setting for adjustment of the angle	Setting for adjustment of the angle Disconnect the DMX signal and adjust the angle selection. It can be adjusted to full angle mode and other fixed angle modes. When adjusting to the full-angle mode, you need to place the limit bar on the protective fence to the maximum angle position, or remove the protective fence. Otherwise, the rotating motor will be damaged and the machine will not rotate normally.
6	Switch ON the machine	Please confirm safety lock located at TEST MODE before switch on the unit.
7	Set DMX address	The unit has 6 channels. Detailed information please refer to DMX channels.

8	Pressurize	Under DMX control: Channel 6= 50~200.
9	Check device status in TEST MODE	Reconfirm safety lock located at TEST MODE before test. In this status, the nozzle will rotate, and igniter will be activated, but there is no flame effect because no fuel output. In case DMX control is used to test the sequence, It is suggested to set CH1 at 128, so that nozzle stays at straight up position after firing.
10	Pressure Relief	Under DMX control: Channel 6= 0~49 or 201~255.
11	Switch safety lock to USER MODE	Before switching to USER MODE, Please strictly follow the safety distance requirement, make sure no human beings, no animal or no flammable objects are within the danger area.
12	Pressurize	Under DMX control: Channel 6= 50~200.
13	Firing	Under DMX control: Channel 3= 255.
14	Pressure Relief	Relief pressure when show finished or Wave flame machine will not be used for a long period. Under DMX control: Channel 6= 0~49 or 201~255.
15	Switch safety lock to TEST MODE	Guarantee safety use for next time.
16	Power off	Power off Wave flame machine, tear down power cable and DMX cable, pack the device when it is cooled down.

5.4.4. Definition of positions

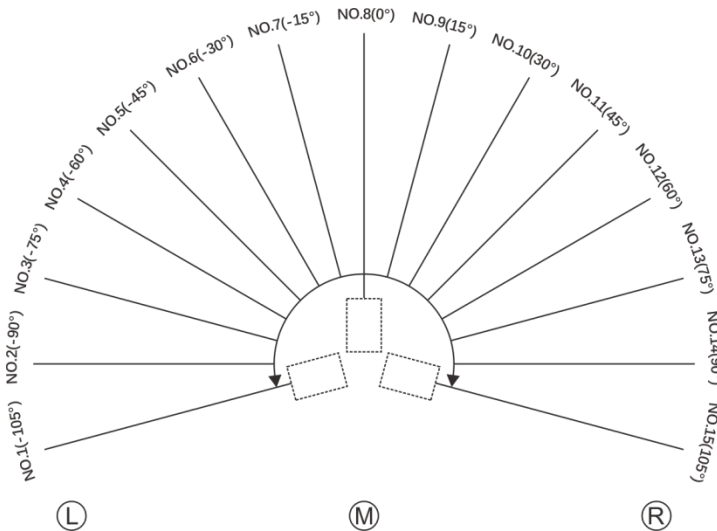

5.4.5. Drive time for Effects

Time needed for the motor drives from NO.8 to relevant angle:

No.	Angles	Drive time needed	Remark
NO.1	-105°	170ms	Hang
NO.2	-90°	150ms	Hang and Horizontal placement model

NO.3	-75°	130ms	Hang and Horizontal placement model
NO.4	-60°	110ms	Hang and Horizontal placement model
NO.5	-45°	90ms	Hang and Horizontal placement model
NO.6	-30°	70ms	Hang and Horizontal placement model
NO.7	-15°	50ms	Hang and Horizontal placement model
NO.8	0°	0ms	Hang and Horizontal placement model
NO.9	15°	50ms	Hang and Horizontal placement model
NO.10	30°	70ms	Hang and Horizontal placement model
NO.11	45°	90ms	Hang and Horizontal placement model
NO.12	60°	110ms	Hang and Horizontal placement model
NO.13	75°	130ms	Hang and Horizontal placement model
NO.14	90°	150ms	Hang and Horizontal placement model
NO.15	105°	170ms	Hang model

For example, it takes 90ms for the motor drives from 0° to 45° . When operator design a show to synchronize to music, this drive time must be taken into account.

5.4.6. Control of Flamer

HF-210S has 80 preset sequences, operator can use related channel DMX value or sequence No. to access certain sequence. Below is the sequence list and single ignitions.

Single Ignition Sequence List:

No.	Ignition angle	Description	Nozzle Movement	Firing Duration (For reference)	CH5 DMX Reference Value
1	Hang model -105°	Single Ignition SHORT flame	Static	0.19s	3-5
	Horizontal placement model -90°				
2	-90°	Single Ignition SHORT flame	Static	0.19s	6-8
3	-75°	Single Ignition SHORT flame	Static	0.19s	9-11
4	-60°	Single Ignition SHORT flame	Static	0.19s	12-14
5	-45°	Single Ignition SHORT flame	Static	0.19s	15-17
6	-30°	Single Ignition SHORT flame	Static	0.19s	18-20
7	-15°	Single Ignition SHORT flame	Static	0.19s	21-23
8	0°	Single Ignition SHORT flame	Static	0.19s	24-26
9	15°	Single Ignition SHORT flame	Static	0.19s	27-29
10	30°	Single Ignition SHORT flame	Static	0.19s	30-32
11	45°	Single Ignition SHORT flame	Static	0.19s	33-35
12	60°	Single Ignition SHORT flame	Static	0.19s	36-38
13	75°	Single Ignition SHORT flame	Static	0.19s	39-41
14	90°	Single Ignition SHORT flame	Static	0.19s	42-44
15	Hang model 105°	Single Ignition SHORT flame	Static	0.19s	45-47
	Horizontal placement model 90°				
16	Hang model -105°	Single Ignition SHORT flame	Static	0.56s	48-50
	Horizontal placement model -90°				
17	-90°	Single Ignition SHORT flame	Static	0.56s	51-53
18	-75°	Single Ignition SHORT flame	Static	0.56s	54-56

19	-60°	Single Ignition SHORT flame	Static	0.56s	57-59
20	-45°	Single Ignition SHORT flame	Static	0.56s	60-62
21	-30°	Single Ignition SHORT flame	Static	0.56s	63-65
22	-15°	Single Ignition SHORT flame	Static	0.56s	66-68
23	0°	Single Ignition SHORT flame	Static	0.56s	69-71
24	15°	Single Ignition SHORT flame	Static	0.56s	72-74
25	30°	Single Ignition SHORT flame	Static	0.56s	75-77
26	45°	Single Ignition SHORT flame	Static	0.56s	78-80
27	60°	Single Ignition SHORT flame	Static	0.56s	81-83
28	75°	Single Ignition SHORT flame	Static	0.56s	84-86
29	90°	Single Ignition SHORT flame	Static	0.56s	87-89
30	Hang model 105°	Single Ignition SHORT flame	Static	0.56s	90-92
	Horizontal placement model 90°				

Step Sequences List:

No.	Ignition angle NO.	Description	Nozzle movement	Firing Duration (For reference)	CH5 DMX Reference Value
31	Hang model Step 1-15	SHORT flame Step sequence	L -> R	2.57 s	93-95
	Horizontal placement model Step 2-14				
32	Hang model Step 15-1	SHORT flame	R -> L	2.57 s	96-98
	Horizontal placement model Step 14-2				
33	Step 5>8>11	SHORT flame	L -> R	1.00 s	99-101
34	Step 11>8>5	SHORT flame	R -> L	1.00 s	102-104
35	Step 6>10	SHORT flame	L -> R	0.9 s	105-107
36	Step 10>6	SHORT flame	R -> L	0.9 s	108-110
37	Step 4>6>8>10>12	SHORT flame	L -> R	1.30 s	111-113
38	Step 12>10>8>6>4	SHORT flame	R -> L	1.30 s	114-116
39	Step 8>6>10>4>12	SHORT flame	M>L>R>L>R	1.35 s	117-119
40	Step 8>10>6>12>4	SHORT flame	M>R>L>R>L	1.35 s	120-122
41	Hang model Step 1-15	LONG flame Step sequence	L -> R	8.90 s	123-125
	Horizontal placement model Step 2-14				
42	Hang model Step 15-1	LONG flame	R -> L	8.90 s	126-128
	Horizontal placement model Step 14-2				
43	Step 5>8>11	LONG flame	L -> R	2.01 s	129-131
44	Step 11>8>5	LONG flame	R -> L	2.01 s	132-134
45	Step 6>10	LONG flame	L -> R	1.35 s	135-137
46	Step 10>6	LONG flame	R -> L	1.35 s	138-140
47	Step 4>6>8>10>12	LONG flame	L -> R	3.01 s	141-143
48	Step 12>10>8>6>4	LONG flame	R -> L	3.01 s	144-146
49	Step 8>6>10>4>12	LONG flame	M>L>R>L>R	2.67 s	147-149
50	Step 8>10>6>12>4	LONG flame	M>R>L>R>L	2.67 s	150-152

Wave Sequence List:

No.	Ignition angle NO.	Description	Nozzle movement	Firing Duration (For reference)	CH5 DMX Reference Value
51	Wave 5 -->11	Middle wave sequence	L -> R	1.99 s	153-155
52	Wave 11-->5	Middle wave sequence	R -> L	1.99 s	156-158
53	Big wave hang model 1—15	LONG wave sequence	L -> R	4.14 s	159-161
	Horizontal placement model 2-14				
54	Big wave hang model 15—1	LONG wave sequence	R -> L	4.14 s	162-164
	Horizontal placement model 14-1				
55	Wave Hang model 8-->1	Middle wave sequence	M -> L	2.18 s	165-167
	Horizontal placement model 8-2				
56	Wave Hang model 8-->15	Middle wave sequence	M -> R	2.18 s	168-170
	Horizontal placement model 8-->14				
57	Wave Hang model 1-->8	Middle wave sequence	L -> M	2.16 s	171-173
	Horizontal placement model 2-8				
58	Wave Hang model 15-->8	Middle wave sequence	R -> M	2.16 s	174-176
	Horizontal placement model 14-8				
59	Wave 8-->11	SHORT wave sequence	M -> R	1.12 s	177-179
60	Wave 8-->5	SHORT wave sequence	M -> L	1.12 s	180-182
61	Wave 5-->8	SHORT wave sequence	L -> M	1.24 s	183-185
62	Wave 11>--8	SHORT wave sequence	R -> M	1.24 s	186-188
63	Step 2>14	SHORT flame Step sequence	L -> R	2.16 s	189-191
64	Step 14>2	SHORT flame Step sequence	R -> L	2.16 s	192-194
65	Step 2>14	LONG flame Step sequence	L -> R	7.62 s	195-197
66	Step 14>2	LONG flame Step sequence	R -> L	7.62s	198-200

67	Step 8>14	SHORT flame Step sequence	M -> L	1.08 s	201-203
68	Step 8>2	SHORT flame Step sequence	M -> R	1.08s	204-206
69	Step 8>14	LONG flame Step sequence	M -> L	3.81s	207-209
70	Step 8>2	LONG flame Step sequence	M -> R	3.81s	210-212
71	Step 3>13	SHORT flame Step sequence	L -> R	1.8s	213-215
72	Step 13>3	SHORT flame Step sequence	R -> L	1.8s	216-218
73	Step 4>12	SHORT flame Step sequence	L -> R	1.4s	219-221
74	Step 12>4	SHORT flame Step sequence	R -> L	1.44s	222-224
75	Step 5>11	SHORT flame Step sequence	L -> R	1.08s	225-227
76	Step 11>5	SHORT flame Step sequence	R -> L	1.08s	228-230
77	Step 7>9	SHORT flame Step sequence	L -> R	0.36s	231-233
78	Step 9>7	SHORT flame Step sequence	R -> L	0.36s	234-236
79	Step 3>13	LONG flame Step sequence	L -> R	6.35s	237-239
80	Step 13>3	LONG flame Step sequence	R -> L	6.35s	240-242
81	Step 4>12	LONG flame Step sequence	L -> R	5.08s	243-245
82	Step 12>4	LONG flame Step sequence	R -> L	5.08s	246-248
83	Step 5>11	LONG flame Step sequence	L -> R	3.81s	249-251
84	Step 11>5	LONG flame Step sequence	R -> L	3.81s	252-254
85	Step 7>9	LONG flame Step sequence	L -> R	1.27s	255

5.4.7. DMX CONTROL

Channel	Function	Value	Setting	
(CH1)	Angle	6~249	Hang model : -105° to 105°	
(CH2)	Speed		1~254	Horizontal placement model : -90° to 90°, 128, 0-5, and 250-255 all is straight upward.
			255	Speed increases
(CH3)	Ignition	0~253	Max speed	
			Ignition OFF	

		254~255	Ignition ON
(CH4)	Opening time	0	Permanent fire
		1~254	In steps of 10ms, to 2540ms Opening time= DMX Value * 10ms
		255	Permanent fire
(CH5)	Program Sequence	0~2	No preset sequence
		3~255	Preset sequence. Sequence No.= DMX value÷3 (round numbers)
(CH6)	Mode	0~49	Pressure Relief Mode (Emergency Stop)
		50~200	Compression Mode
		201~255	Pressure Relief Mode (Emergency Stop)

5.4.7.1. About Channel

1. The first channel controls the firing angle. It defines to which angle the nozzle of Wave flame machine move to. This angle was set Hang model : -105° to 105° or Horizontal placement model : -90° to 90° in anywhere.

2. The DMX value for angle of 0° is 127.5 (round up 128). Use this value, following formula can be used to calculate all other angles ∠ in degree. Please always note the prefix of the angle.

$$\text{DMX Value} = 127.5 + (\angle * 1.2145)$$

(CH1) : Angle

Angle No.	Angle	DMX Value
1	Hang model -105°	6
	Horizontal placement model -90°	
2	-90°	24
3	-75°	42
4	-60°	60
5	-45°	79
7	-15°	97
8	0°	115
9	15°	128
10	30°	140
11	45°	159
12	60°	177
13	75°	195
14	90°	213
15	Hang model 105°	249
	Horizontal placement model 90°	

(CH2) : Speed

CH2: Speed Setup			
DMX Value	0	1-254	255
Speed	Max Speed	Incremental of Speed	Max Speed

The second channel defines the rotating speed. It work together with Channel 1 for manual firing

(CH3) : Ignition

CH3: Ignition		
DMX Value	0-253	254-255
Firing	Wave flame machine won't ignite	Wave flame machine ignites

The third channel activates the actual ignition. If the DMX value of this channel higher than 253, the Wave flame machine will ignite.

(CH4) : Opening time

CH4: Manual Firing Duration setup							
DMX Value	0	1	2	3	254	255
Firing Duration	Permanent	10ms	20ms	30ms		2540ms	Permanent

The fourth channel is the firing duration setup. Below formula can be used to calculate the firing duration (ms): DMX Value = t/10

(CH5) : Channel 5 (CH5): Program Sequence

The fifth Channel allows to firing a preset sequence. Three DMX values can be used for one of the programmed firing sequence from above sequence list (refer to above sequence list table). Below formula can be used to calculate firing sequence:

Sequence No.= DMX Channel Value÷3

CH5: Sequence List							
DMX Value	0~2	3~5	6~7	8~10	11~12	255
Sequence No.	N/A	1	2	3	4		85

Note:Channel 5 overrides Channel 1, 2, 3, and 4 in case the value is from 3~255.

(CH6): Channel 6 Mode

The sixth channel is the working mode of pump

When the safety lock located at TEST MODE, set DMX value between 50-200 to test the system. For safety, the device will not Pressurize. When the safety lock located at USER MODE, the device Pressurize activated by set DMX value between 50-200. The device can only make ignitions in Firing mode.

CH6: Mode setup			
DMX Value	0-49	50-200	201-255
Mode	Pressure Relief Mode	Firing Mode	Pressure Relief Mode

5.4.7.2. DMX console control

1. Set nozzle straight up

- 1) (CH1 Angle = 128, CH2 Speed = 0, CH3 Ignition = 0, CH4 Opening time = 0, CH5 Program sequence = 0, CH6 Firing mode = 50~200)
- 2) Set preset Sequence No. 31 (CH1 Angle = 128, CH2 Speed = 0, CH3 Ignition = 0, CH4 Opening time = 0, CH5 Program sequence DMX value = 94 , CH6 Firing mode = 50~200)
- 3) Ignition (CH1 Angle = 128, CH2 Speed = 0, CH3 Ignition = 255, CH4 Opening time = 0, CH5 Program sequence DMX value =94 , CH6 Firing mode = 50~200)

Note: After firing, the DMX value of CH3 must back to 0, before an ignition can be made again. CH1 determines the nozzle direction after firing.

2. Example of set Wave Flame effect not from preset-sequence

- 1) Set nozzle to the start point (CH1 Angle = 0, CH2 Speed = 255, CH3 Ignition = 0, CH4 Opening time = 0, CH5 Program sequence = 0, CH6 Firing mode = 50~200)
- 2) Set moving speed (CH1 Angle = 0, CH2 Speed = 50, CH3 Ignition = 0, CH4 Opening time = 0, CH5 Program sequence = 0, CH6 Firing mode = 50~200)
- 3) Set firing end point and ignition (CH1 Angle = 255, CH2 Speed = 50, CH3 Ignition = 255, CH4 Opening time = 0, CH5 Program sequence = 0, CH6 Firing mode = 50~200)
- 4) Firing Nozzle will firing and make movement from start point to end point

Note: After firing, The DMX value of CH3 must back to 0, before an ignition can be made again. Make sure CH 5 = 0~2.

3. Example of firing with fixed duration

- 1) Set nozzle straight up (CH1 Angle = 128, CH2 Speed = 0, CH3 Ignition = 0, CH4 Opening time = 0, CH5 Program sequence = 0, CH6 Firing mode = 50~200)
- 2) Set firing duration 1s (CH1 Angle = 128, CH2 Speed = 0, CH3 Ignition = 0, CH4 Opening time = 100, CH5 Program sequence = 0, CH6 Firing mode = 50~200) (Note: Opening time = DMX value * 10ms [1s])
- 3) Firing 1s (CH1 Angle = 128, CH2 Speed = 0, CH3 Ignition = 255, CH4 Opening time = 100, CH5 Program sequence = 0, CH6 Firing mode = 50~200)

Note: After firing, The DMX value of CH3 must back to 0, before an ignition can be made again

6. MAINTENANCE

1. To maintain the system in good performance and running status, it is recommended to running the device at least once per month.
2. In order to lubricate the pipeline and pump it is highly necessary to add 10-20ml castor oil per 10L canister.



It must not be pressurized without fuel in the tank, otherwise it will cause damage to the main board and the pump.

WWW.DJPOWER.CN