

# 1 BEFORE YOU BEGIN

## 1.1 What Is Included



D-WP2 Bubble Fog Machine × 1                      Power Cord × 1                      Wireless Remote × 1                      Warranty Card × 1

## 1.2 Unpacking Instructions

Carefully unpack the product immediately and check the container to make sure all the parts are in the package and are in good condition.

If the box or the contents (the product and included accessories) appear damaged from shipping, or show signs of mishandling, notify the carrier or dealer/seller immediately. In addition, keep the box and contents for inspection.

## 1.3 Symbols

Symbol	Meaning
	Caution Critical installation, configuration, or operation information. Not following these instructions may make the product not work, cause damage to the product, or cause harm to the operator.
	Important Important installation or configuration information. Failure to comply with this information may keep the product from working correctly.
	Information Useful information.

## 1.4 Disclaimer

The information and specifications contained in this User Manual are subject to change without notice. DJPOWER assumes no responsibility or liability for any errors or omissions and reserves the right to revise or to create this manual at any time.

Copyright © 2025 DJPOWER. All rights reserved.

## 1.5 Safety Notes

Please read the following Safety Notes carefully before working with the product. The notes include important safety information about installation, usage, and maintenance.

### 1.5.1 Personal Safety

- Always connect the product to a grounded circuit to avoid the risk of electrocution.
- The machine is for adults only, and keep children out of reach of the machine!

### 1.5.2 Mounting and Rigging

	In order to prevent the liquid from splashing to the ground after the bubbles burst, causing the ground to be slippery, it is recommended to use a layer of absorbent cotton on the floor of the machine to prevent slipping. When the machine is used in a suspended position, the bottom of the
--	---

machine should be kept away from people or important objects. After using, liquids scattered on the ground should be cleaned up promptly to prevent people from slipping.

- The product is for indoor use only! To prevent risk of fire or shock, do not expose the product to rain or moisture.
- CAUTION: When transferring product from extreme temperature environments, (e.g. cold truck to warm humid ballroom) condensation may form on the internal electronics of the product. To avoid causing a failure, allow product to fully acclimate to the surrounding environment before connecting it to power.
- Do not mount the product on a flammable surface (linoleum, carpet, wood, paper, carton, plastic, etc.).
- Do not use in a confined space. Always install the product in a location with adequate ventilation, at least 20 inch (50 cm) from adjacent surfaces.
- Be sure that no ventilation slots on the product's housing are blocked.
- When the machine is hung, please use a hanging device to securely tie it to the truss.

### 1.5.3 Power and Wiring

- Always make sure that the voltage of the outlet to which you are connecting the product is within the range stated on the decal or rear panel of the product.
- Make sure the power cord is not crimped or damaged.
- Never connect this product to a dimmer pack or rheostat.
- Never disconnect the product from power cord by pulling or tugging on the cord.
- To eliminate unnecessary wear and improve its lifespan, during periods of non-use completely disconnect the product from power via breaker or by unplugging it.

### 1.5.4 Operation

- Do not operate this product if you see damage to the housing or cables. Have the damaged parts replaced by an authorized technician at once.
- Do not use this machine as a space heater.
- Make sure there are no flammable materials close to this product while it is operating.
- The maximum ambient temperature (Ta) is 104 °F (40 °C). Do not operate the product at higher temperatures.
- Do not cover the ventilation slots when operating to avoid internal overheating.
- Do not cover or block the nozzle during operation.
- Never carry the product by the power cord or any moving part. Always use the handles.
- Drain the tank before transporting the product. Bubble fluid or the fog fluid tanks shall be used for the relevant fluid only.
- Always disconnect the product from the power source before cleaning.
- In the event of a serious operating problem, stop using the product immediately.
- This product contains no user -serviceable parts. Any reference to servicing in this User Manual will only apply to properly trained, certified technicians. Do not open the housing or attempt any repairs which can lead to damage or malfunction.
- Use only DJPOWER Consumable. Bubble fluid PRO-PW and fog fluid PRO-C or PRO-J are recommended.
- Please save this manual for future use. When resell the machine, be sure to attach the instruction.

## 2 INTRODUCTION

### 2.1 Description

D-WP2 is a newly launched, jet-design dual-nozzle bubble machine from DJPOWER. Its housing is injection-molded with ABS+PC material, making it lightweight, rust-proof, and corrosion-resistant. The jet-design creates lots of vivid bubbles filled with fog while with less fog outside, effectively avoiding the issue of excessive fog affecting the performance. An efficient and stable heating system prevents unwanted spraying of water or fluid during operation, and the super silent fan allows the bubbles to travel farther. The nozzle is equipped with 24 three-in-one LED lights, offering higher brightness that harmonizes with the bubble effect, creating a more enchanting visual experience. The adjustable air outlet allows you to control the flight height and distance of the bubbles. The quick-disconnect fluid tank design enables faster fluid replacement and more convenient use. The bubble fluid and fog fluid are well stored and sealed in the tank without going bad even after long time to ensure high quality show. Ideal for various applications including stage performances, product launches, bars, and many other events.

### 2.2 Features

- Featuring injection-molded ABS+PC construction, the housing is lightweight, rust-proof, and corrosion-resistant;
- Innovative jet design, create denser and beautiful fog bubbles, greatly reducing the formation of excess fog;
- The efficient and stable heating system ensures operation free from water or fluid spraying;
- The super silent fan operates at a noise level below 55dB(A) under normal conditions, making the bubble fog travel farther;
- The dual temperature control and protection system ensures safer and more reliable operation;
- Equipped with 24 three-in-one LED lights, offering higher brightness that harmonizes with the bubble effect, creating a more enchanting visual experience;
- The fans with adjustable angles make the bubble fog fly higher and further;
- The quick-connect fluid tank design enables faster and more efficient fluid replacement.;
- Designed with clear labeling to prevent mixing and incorrect installation of bubble fluid and fog fluid, making the machine more user-friendly.

Please use DJPOWER special bubble fluid PRO-PW and fog fluid PRO-C. After use, please carry out regular cleaning and maintenance.

Note: The actual effect may be affected by the using environment.

### 2.3 Product Overview

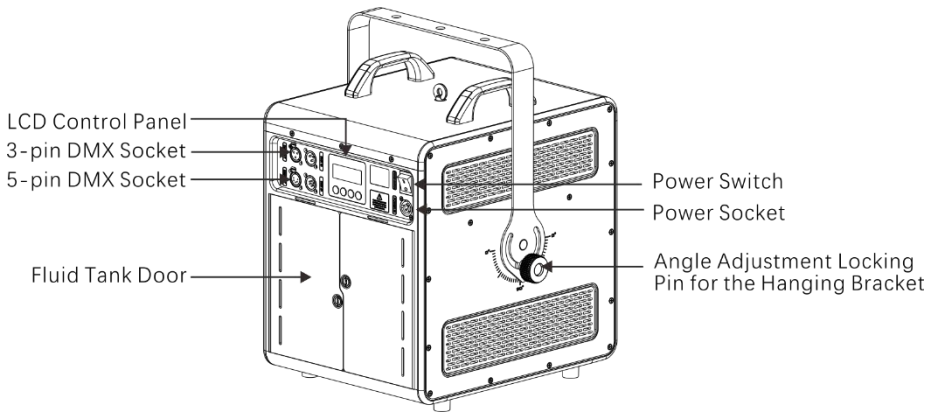
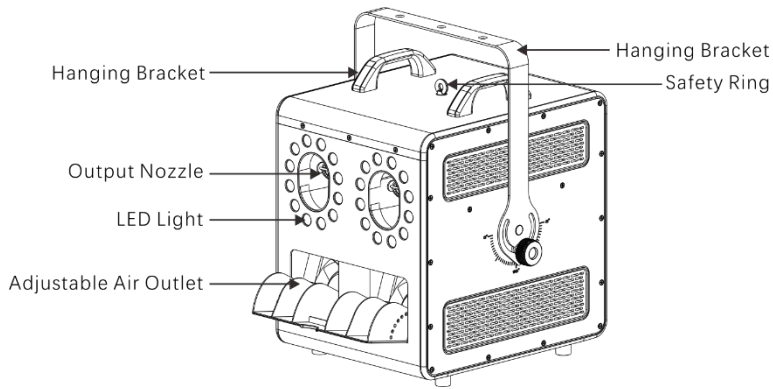

## 2.4 Product Dimensions

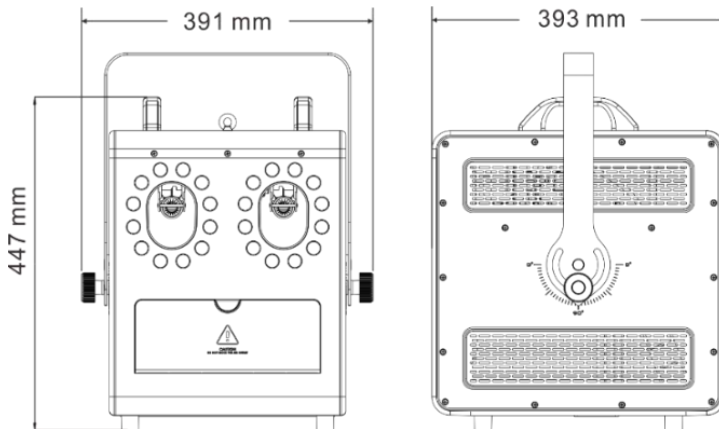

## 3 TECHNICAL SPECIFICATIONS

AC Power	Input Voltage & Rate	AC 100-120 V, 50/60 Hz	AC 220-240 V, 50/60 Hz
----------	----------------------	------------------------	------------------------

	Current Limiter Specifications	8 A, 250 V	5 A, 250 V
	Total Power Consumption	550 W	
Heating	Heat Up Time	Appr. 3 min 15 s	
Light Source	LED Color	RGB	
	LED Type	Three-in-one	
	Power per LED	1.5 W	
	Quantity of LED	24 pcs	
	Total LED Power	36 W	
Capacity	Bubble Fluid Tank Capacity	4 L	
	Fog Fluid Tank Capacity	4 L	
Output	Adjustable Output	√	
	Max Fog Output Volume	Appr. 4,500 cuft/min	
	Max Output Height	Appr. 6 m	
	Max Output Distance	Appr. 6 m	
	Fog Fluid Consumption (100% Output)	Appr. 74 min/L	
	Bubble Fluid Consumption (100% Output)	Appr. 40 min/L	
Placement & Mounting	Horizontal	√	
	Inclined	×	
	Sidelong	×	
	Hang Upside Down	×	
	Rigging & Trussing	√	
Control	On-device Manual Control	LCD Control Panel	
	Wireless Control	W-4	
	Wired Control	×	
	Control Protocol	DMX512	
	DMX Channel Range	11	
Consumable	Consumable	PRO-PW and PRO-Cor PRO-J	
Weight & Dimensions	Net Weight	10 kg	
	Gross Weight	12 kg	
	Machine Dimensions	391 × 393 × 447 mm	
	Packing Dimensions	467 × 400 × 560 mm	

## 4 SETUP

### 4.1 AC Power

The machine has two kinds of voltage power supply, it can work with an input voltage of AC 100V -120V, 50/60 Hz or AC 220V-240V, 50/60 Hz, depending on the specific model.

To determine the product's power requirements (circuit breaker, power outlet, and wiring), use the current value listed on the label affixed to the product's back panel, or refer to the product's specifications chart.

The listed current rating indicates the product's average current draw under normal conditions.



Always connect the product to a protected circuit (circuit breaker or fuse). Make sure the product has an appropriate electrical ground to avoid the risk of electrocution or fire.



Never connect the product to a rheostat (variable resistor) or dimmer circuit, even if the rheostat or dimmer channel serves only as a 0 to 100% switch.

### 4.2 AC Plug

D-WP2 comes with a power input cord terminated with a lockable power connector on one end. The other end is

- CN plug (CN market, etc.)
- EU plug (EU market, etc.)
- US plug (US market, etc.)

If the power input cord that came with your product has no plug, or if you need to change the plug, use the table below to wire the new plug:

	Wire (U.S.)	Wire (Europe)
<b>AC Live</b>	Black	Brown
<b>AC Neutral</b>	White	Blue
<b>AC Ground</b>	Yellow	Green/Yellow

### 4.3 DMX Linking

You can link the D-WP2 to a DMX controller using a 3-pin or 5-pin DMX connection. If using other DMX compatible products with this product, you can control each individually with a single DMX controller. Instructions for connecting and configuring this product for DMX operation are in the User Manual.

### 4.4 Mounting

Before mounting the product, read and follow the safety recommendations indicated in the Safety Notes.

#### 4.4.1 Orientation

Operate the product while it is on the ground only, and make sure there is adequate room for ventilation, configuration, and maintenance.

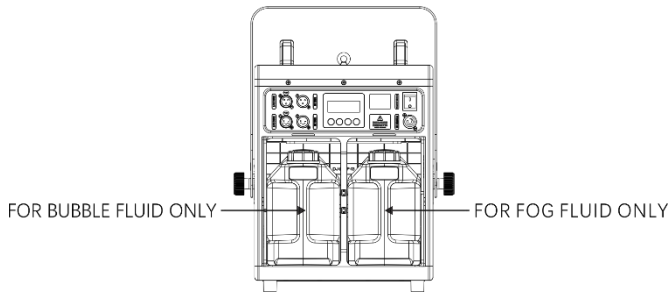

**⚠ Do not mix the bubble fluid and fog fluid**

#### 4.4.2 Rigging

Using the following general guidelines when mounting this product

- Before deciding on a location for the product, make sure there is easy access to the product for maintenance and programming purposes.
- Make sure that the structure or surface onto which you are mounting the product can support the product's weight (see the Technical Specifications).
- When mounting the product on the floor, make sure that the product and cables are away from people and vehicles.

## 5 OPERATION

### 5.1 Preparing for Operation

Before operating the machine, please follow the following steps to prepare:

- After checking that all the parts are intact and complete, position the machine on flat.
- Withdraw the fluid tank from its compartment and remove its cap. Add bubble fluid and fog fluid to the specified tank
- Always connect the product to a grounded circuit. Before power on, make sure it is connected with the rated voltage.

### 5.2 On-device Control Mode & Operation

The conditions for meeting this method are: disconnect the DMX signal (when the DMX signal is connected, the LCD control mode is invalid and only the DMX address code can be set).

When operating the control panel, use the four buttons below the LCD display.

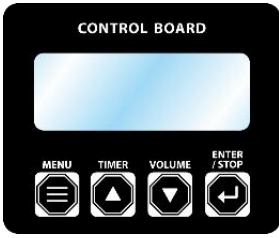

Button	Function
<MENU>	Switch menu pages to select a function
<▲>	Increases the numeric value of current function Trigger TMER output mode
<▼>	Decreases the numeric value of current function Trigger Manual output mode
<ENTER>	Save settings STOP turns the fog output off

### 5.2.1 Menu Map

	Display	Description	Adjustment range
Standby page	Warming Up 1% D-WP2	The unit is heating.	
	Ready To Work D-WP2	Heating completed, ready to work.	
	Bubble Output ON	Press ▲ and ▼ button to set bubble output.	ON/OFF
	Haze Output 100%	Press ▲ and ▼ button to set haze output.	1%-100%
Setting Pages	Fan Speed 100%	Press ▲ and ▼ button to set the Fan Speed	1%-100%
	Remote Control Function ON	Press ▲ and ▼ button to set the remote control function.	ON/MATCH/OFF
	Color Setting RED	Press ▲ and ▼ to set the LED light color.	OFF/Red/Orange/Yellow/Green/Cyan/Blue/Purple/White/Auto Color
	Liquid Level light ON	Press▲and ▼ to set the Liquid Level light	ON/OFF
	DMX Address 1	Press ▲ and ▼ button to set DMX starting address.	1 - 512

Auto run last settings ON	Press ▲ and ▼ button to turn on or off the function. After the machine is powered off and restarted, it will remember the last running status of the machine.	ON/OFF
Clean Mode ON	Press ▲ and ▼ button to set cleaning mode ON/OFF. When cleaning mode is ON, the machine will be in the cleaning state and will not work properly until it is OFF.	ON/OFF
Auto Screen Off ON	Press ▲ and ▼ to set the auto screen off function ON/OFF. When it turn ON, the screen will automatically turn off after 30 seconds of no operation. Press any button to reactive the screen.	ON/OFF
Language English	Press ▲ or ▼ to select the language and save by ENTER.	Chinese / English

Press <STOP> on any page to exit/return to the first page.

Press <STOP> in working status to stop working and return to the first page.

After entering the relevant page, press "▲" and "▼" to change the current settings.

Press the <TIMER> key on the first page to enter the timing function. The relevant instructions are as follows:

Display	Description	Adjustment Range
Timer Interval 10S D-WP2		
Timer Duration 10S D-WP2		

**Timing Function**

The display will cycle through these pages. The time (such as 10S) is based on the currently set value (as configured on the 1st and 2nd pages).

When on the first page, pressing the <VOLUME> key will initiate the operational mode. Related instructions are as follows:

Bubble Output ON Haze Output 100%	Press ▲ or ▼ to set the volume of the bubble output and Haze output.	ON/OFF 1%-100%
--------------------------------------	--	----------------

### 5.3 Wireless Remote-Control Mode & Operation

The wireless remote control allows for the remote operation of the machine. This function is only active when the remote control is turned on and no DMX signal is connected.

D-WP2 can be operated with the W-4 wireless controller. The W-4 features two buttons: press "ON" to start the unit and "OFF" to stop it. A single unit



can recognize up to ten transmitters with different codes, which enables individual control of multiple units without cross-interference.

### 5.3.1 Transmitter Pairing

To identify a wireless transmitter, power on the machine and navigate to the remote control function page. Set the parameter to "Match". Then, press and hold any button on the transmitter for at least one second. If the backlight on the LCD controller flashes twice, it indicates that the transmitter has been successfully identified. A single machine can store a maximum of 10 transmitters. When an 11th transmitter is identified, the first (oldest) one in the memory will be erased.

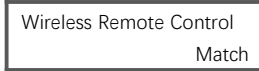

If ten transmitters were already stored from the previous session, identifying at least one new transmitter during the current power-on will cause the earliest stored transmitter to be erased. The parameter will automatically revert to "On" after exiting the "Remote Control Function" page, whether done manually or due to a timeout.

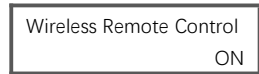

### 5.4 DMX Mode & Operation

D-WP2 can work with a DMX controller.

After the machine is connected to the DMX signal, the LCD screen can only display the DMX512 address setting page. At this time, you can set and modify the DMX512 address code by pressing the "▲" or "▼" button.

#### Machine has 11 DMX channels: as below

DMX Function	Channel 1	Bubble Output	0-128	OFF
			129-255	ON
	Channel 2	Fog Output	0-10	OFF
			11-255	Fog volume, low to high
	Channel 3	Wind Output	0-10	OFF
			11-255	Fan speed, low to high
	Channel 4	Cleaning Mode	0-128	OFF
			129-255	ON
	Channel 5	RED	0-10	OFF
			11-255	Dim to bright
	Channel 6	GREEN	0-10	OFF
			11-255	Dim to bright
	Channel 7	BLUE	0-10	OFF
			11-255	Dim to bright
	Channel 8	Color Mixing	0-255	Gradual change
	Channel 9	Auto Color Change Speed	0-10	OFF
			11-255	Slow to Fast

		Adjustment		
Channel 10	Strobe		0-10	OFF
			11-255	Slow to Fast
Channel 11	Dimming Control		0-10	OFF
			11-255	Dim to bright

## 6 TECHNICAL INFORMATION

### 6.1 Maintenance

After each time use of the bubble fog machine, it is necessary to clean the nozzles with clean water in time to prevent the residual bubble liquid on the nozzles from solidifying and gluing, which will cause it to fail to be used normally next time!

D-WP2 requires regular cleaning and maintenance to achieve the best performance. Some cleaning and maintenance steps are essential. Here are the recommended steps for cleaning:

- 1) Unplug the product from power.
- 2) Empty bubble & haze fluid from the machine.
- 3) Add water to the bubble fluid tank.
- 4) Connect the product to power and allow it to warm up. Turn on the cleaning mode, and the machine will automatically pump clean water into the machine to clean the bubble output nozzles and tubes.
- 5) Run the product in a well -ventilated area. Do not allow the pump to run dry!
- 6) Excessive dust, fluid residue and dirt will degrade performance and cause overheating. Remove dust from air vents with air compressor, vacuum or soft brush. The casing could be cleaned by the damp cloth.



**Test-run your DJPOWER ®D-WP2 on a monthly basis to achieve the best performance.**

### 6.2 Storage

#### 6.2.1 Machine Storage

Before storing the machine, clean it and empty the fluid tank.