

TOPCAT[®]

by DJPOWER

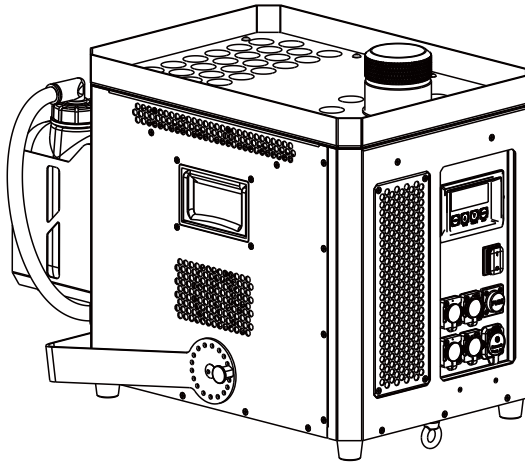

H-20V TOPCO2JET

USER MANUAL

GUANGZHOU DJPOWER ELECTRONIC TECHNOLOGY CO.,LTD

1 BEFORE YOU BEGIN

1.1 What Is Included

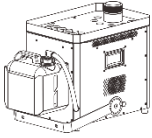

H-20V × 1



Power Cord × 1



Warranty Card × 1



Optional (extra fee): bracket base to meet the needs of different scenarios

1.2 Unpacking Instructions

Carefully unpack the product immediately and check the container to make sure all the parts are in the package and are in good condition.

If the box or the contents (the product and included accessories) appear damaged from shipping, or show signs of mishandling, notify the carrier or dealer/seller immediately. In addition, keep the box and contents for inspection.

1.3 Symbols

Symbol	Meaning
	Caution Critical installation, configuration, or operation information. Not following these instructions may make the product not work, cause damage to the product, or cause harm to the operator.
	Important Important installation or configuration information. Failure to comply with this information may keep the product from working correctly.
	Information Useful information.

1.4 Disclaimer

The information and specifications contained in this User Manual are subject to change without notice. DJPOWER assumes no responsibility or liability for any errors or omissions and reserves the right to revise or to create this manual at any time.

Copyright © 2024 DJPOWER. All rights reserved.

1.5 Safety Notes

Please read the following Safety Notes carefully before working with the product. The notes include important safety information about installation, usage, and maintenance.

1.5.1 Personal Safety

- Always connect the product to a grounded circuit to avoid the risk of electrocution.
- During heating up and operation, the housing will be scalding hot. Do not touch.
- **The product is very hot during operation and it remains hot for a long time after operation has stopped. Do not touch the product's nozzle. Keep a distance of 100cm between nozzle and person.**
- **Make sure that children, unauthorized people and animals do not obtain access to the machine.**
- **Avoid direct eye exposure to the light source while the product is on.**

1.5.2 Mounting and Rigging

- This machine is not designed to be rainproof. Please keep the machine dry and do not expose it to rain or humid environment.
- CAUTION: When transferring product from extreme temperature environments, (e.g. cold truck to warm humid ballroom) condensation may form on the internal electronics of the product. To avoid causing a failure, allow product to fully acclimate to the surrounding environment before connecting it to power.
- Do not mount the product on a flammable surface (linoleum, carpet, wood, paper, carton, plastic, etc.).
- Do not use in a confined space. Always install the product in a location with adequate ventilation, at least 20 in (50 cm) from adjacent surfaces.
- When hanging this product, always secure to a fastening device using a safety cable. And turn the oil bottle mouth upwards.
- Be sure that no ventilation slots on the product's housing are blocked or clogged by dust. If necessary, remove the dust.

1.5.3 Power and Wiring

- Always make sure that the voltage of the outlet to which you are connecting the product is within the range stated on the decal or rear panel of the product.
- Make sure the power cord is not crimped or damaged.
- Never connect this product to a dimmer pack or rheostat.
- Never disconnect the product from power cord by pulling or tugging on the cord.
- To eliminate unnecessary wear and improve its lifespan, during periods of non-use completely disconnect the product from power via breaker or by unplugging it.

1.5.4 Operation

- Do not operate this product if you see damage to the housing or cables. Have the damaged parts replaced by an authorized technician at once.
- Do not use the product as a space heater.
- The maximum ambient temperature (Ta) is 104 °F (40 °C). Do not operate the product at higher temperatures.
- **Do not cover the ventilation slots when operating to avoid internal overheating.**

- **Do not cover or plug the output nozzle during operation.**
- Wipe up spitted fluid immediately. Moisture – also fluid – can destroy the electric.
- You may hear a loud popping sound during operation. This is normal.
- Never carry the product by the power cord or any moving part. Always use the handles of the machine.◦
- **Drain the tank before transporting the product.**
- Always disconnect the product from the power source before cleaning.
- In the event of a serious operating problem, stop using the product immediately.
- This product contains no user-serviceable parts. Any reference to servicing in this User Manual will only apply to properly trained, certified technicians. Do not open the housing or attempt any repairs which can lead to damage or malfunction.
- **Use only DJPOWER Consumable, fog fluid PRO-20V is recommended.**



Keep this User Manual for future use. If you sell the product, be sure that the purchaser receives this document.

2 INTRODUCTION

2.1 Description

H-20V is a new dual-nozzle super jet fog machine launched by DJPOWER. It can achieve rapid air column effects without the need of CO2 cylinders. High-speed airflow assist technology enhances fog spray speed. The dual-nozzle design can spray up to 15-meterhigh air column with majestic effects! it has 37pcs of 8W LEDs, producing strong and colorful air columns. The machine has independent R&D high-speed airflow assist patent (No: ZL202023001465.9), Super-jet patent (No: ZL201520934500.2), Immediate-stop patent (No:ZL201320700998.7). It's suitable for large-scale performances, bars, cultural tourism projects etc.

2.2 Features

- High-speed airflow assist technology, rapid eruptions and quick dissipation; Dual-Nozzle design, majestic fog columns;
- Super jet and immediate stop functions and fog reaction freely;
- 37pcs of 8W LEDs, stronger air columns;
- Supports side-way, upside down installation and multi-angle spraying;

Please use DJPOWER professional High Density Nano Fog Fluid PRO-20V. It has high density which produces pure, white and dense fog. The nano fog particles can dissipate faster. The effect is more outstanding when used with H-20V.

Note: The actual effect may be affected by the user environment.

2.3 Product Overview

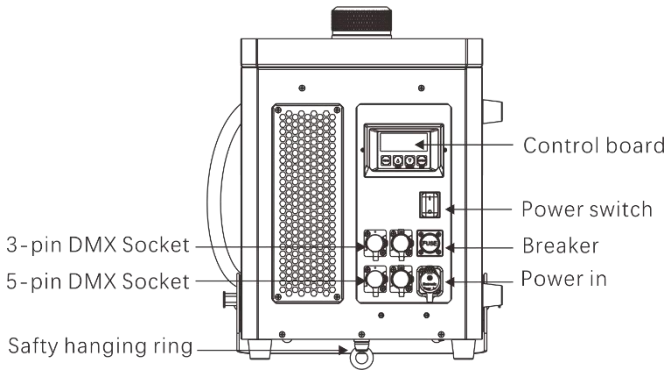
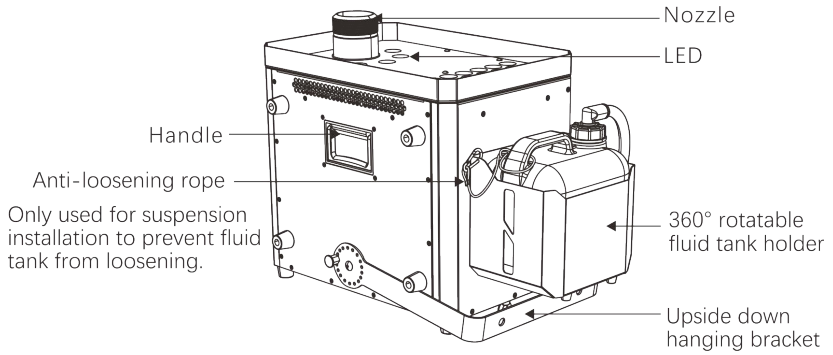

2.4 Product Dimensions

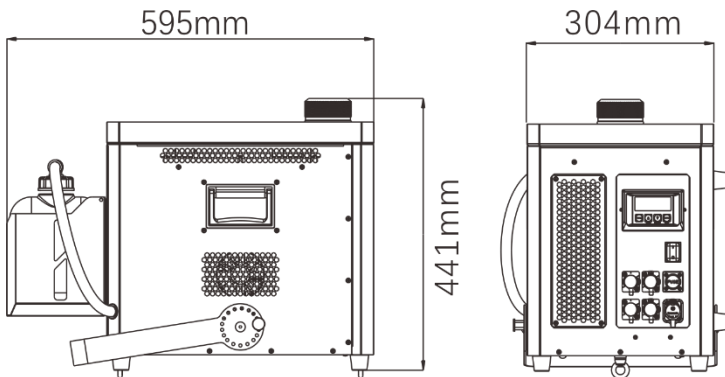

3 TECHNICAL SPECIFICATIONS

AC Power	Input Voltage & Rate	AC 100-120V, 50/60Hz	AC 220-240V, 50/60Hz
	Current Limiter Type	18A/250V	16A/250V
	Total Power Consumption	1,800 W	3,100 W
Heating	Heat Up Time	Appr. 20 min	Appr. 6 min
Light Source	LED color	RGB, Amber	
	LED Power of LED	8 W × 37 pcs	
Tank	Fluid tank	5 L	
Output	Output adjustable	×	
	Max Output Volume	Appr. 117,000 cuft/min	
	Max Output Height	Appr. 15 m	
	Fluid Consumption (100% Output)	Appr. 1.8 min/L	
	Maximum Continuous Duration (100% Output)	Appr. 10 S	
	Continuous Output	×	
	Output Duration with Fluid Tank Full	Appr. 9 min	
Placement & Mounting	Horizontal (Place it on the ground without covering the heat dissipation holes.)	√	
	Inclined	√	
	side lay	√	
	Hang Upside Down	√	
	Rigging & Trussing	√	
Control	On-device Manual Control	LCD control board	
	Wireless Control	×	
	Wired Control	×	
	Control Protocol	DMX512	
	DMX Channel Range	15 or 16	
Consumable	Consumable	PRO-20V	
Weight & Dimensions	N.W.	33 kg	
	G.W.	38 kg	
	Machine Dimensions	595 × 304 × 441 mm	
	Packing Dimensions	725 × 446 × 513 mm	

4 SETUP

4.1 AC Power

The machine has a fixed voltage power supply and can work with an input voltage of AC 100V-120V, 50/60Hz or AC 220V-240V, 50/60Hz, depending on the specific model.

To determine the product's power requirements (circuit breaker, power outlet, and wiring), use the current value listed on the label affixed to the product's back panel, or refer to the product's specifications chart. The listed current rating indicates the product's average current draw under normal conditions.



Always connect the product to a protected circuit (circuit breaker or fuse). Make sure the product has an appropriate electrical ground to avoid the risk of electrocution or fire.



Never connect the product to a rheostat (variable resistor) or dimmer circuit, even if the rheostat or dimmer channel serves only as a 0 to 100% switch.

4.2 AC Plug

The H-20V comes with a power input cord terminated with a Lockable Powercon connector on one end and an EU plug on the other end (EU & China market). If the power input cord that came with your product has no plug, or if you need to change the plug, use the table below to wire the new plug:

Connection	Wire (U.S.)	Wire (Europe)
AC Live	Black	Brown
AC Neutral	White	Blue
AC Ground	Green/Yellow	Green/Yellow

4.3 DMX Linking

You can link the H-20V to a DMX controller using a 3-pin or 5-pin DMX connection. If using other DMX-compatible products with this product, you can control each individually with a single DMX controller. Instructions for connecting and configuring this product for DMX operation are in the User Manual.

4.4 Mounting

Before mounting the product, read and follow the safety recommendations indicated in the Safety Notes.

4.4.1 Orientation

Please install the machine in a safe location and ensure adequate space for ventilation, configuration and maintenance. When hanging upside down, please use the light hook to fix the H-20V; when laying it flat, you can use the rubber feet to place it on a flat surface. Optional (extra fee) bracket base is available to meet the needs of different scenarios.

4.4.2 Rigging

DJPOWER recommends using the following general guidelines when mounting this product

- Before deciding on a location for the product, make sure there is easy access to the product for maintenance and programming purposes.

- Make sure that the structure or surface onto which you are mounting the product can support the product's weight (see the Technical Specifications).
- When mounting the product on the floor, make sure that the product and cables are away from people and vehicles.
- When mounting the product overhead, always use a safety cable. Mount the product securely to a rigging point, whether an elevated platform or a truss.

5 OPERATION

5.1 Preparing for Operation

To prepare the H-20V for operation, perform the following steps:

- After checking that all the parts are intact and complete, position the machine on flat.
- Refill the PRO-20V fluid for machine, damage caused by the use of other fluid is not covered by the warranty.
- Make sure the plastic hose entering the H-20V from the fluid tank cap is not bent or kinked.
- Connect the machine to the appropriate power socket.
- Turn on the machine, and "Heating Up" shows on the display during the heating-up process. After approx. 6 minutes, the display changes to "Ready to Fog" when the machine is ready to output.

5.2 On-device Control Panel

To access the control panel functions, use the four buttons located underneath the LCD display.

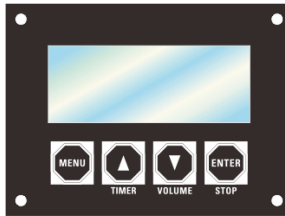

Button	Function
<MENU>	Switch menu pages to select a function
<▲>	Increases the numeric value of current function Triggers Timer output mode
<▼>	Decreases the numeric value of current function Triggers Manual output mode.
<ENTER>	Save settings STOP turns the fog output off

5.3 On-device Control Mode & Operation

5.3.1 Programming

- Refer to the Menu Map to understand the menu options. The menu map shows the main level and a variable number of programming levels for each option.
- To go to the desired main level, press <MENU> repeatedly until the option shows on the display. This will take you to the first programming level for that option.
- To select an option or value within the current programming level, press <TIMER> or <VOLUME> until the option shows on the display. If there is another programming level, you will see that first option, or you will see the selected value.
- Press <MENU> repeatedly to switch menu pages.
- Press <STOP> to go back to Standby Page.

5.3.2 Menu Map

	Display	Description	Parameter Range
Welcome Pages	DJPOWER Version V1	Software version	
	Initializing... H-20V	Initializing	
Preparing Pages	Heating » » » » » » » »	The machine is heating up	
Standby Page	Ready to fog H-20V	Finished heating up, ready to work.	
Setting pages	Timer Interval 600 S	Press "▲" or "▼" to set interval output of TIMER mode	1-600S
	Timer Duration 10 S	Press "▲" or "▼" to duration output of TIMER mode	1-10S
	Manual Output Color 0	Press "▲" or "▼" to set the color of the LED light. "0" turns off the light by default, and 1-17 are 17 different light settings.	0-17
	Fan Idling Mode ON	Press "▲" or "▼" to set whether the fan standby is on or off	ON/OFF
	DMX Address 1	Press "▲" or "▼" to select DMX starting address	1-512
	DMX Address 15 Channel	Press "▲" or "▼" to select 15-channel or 16-channel mode in DMX mode. There is an additional safety channel in 16-channel mode.	15/16

<div style="border: 1px solid black; padding: 5px; text-align: center;"> Auto Run Last Settings ON </div>	<p>After the machine is powered off and restarted, it will remember the last running status of the machine. Press "▲" or "▼" button to turn on or off the function.</p>	ON/OFF
<div style="border: 1px solid black; padding: 5px; text-align: center;"> Auto black out Screen ON </div>	<p>Auto black out screen switch After turning on the auto black out function, the machine will auto black out the screen after 10 seconds without any button operation. Press any button to wake it up. At the same time, DMX control is not affected by screen off.</p>	ON/OFF
<div style="border: 1px solid black; padding: 5px; text-align: center;"> Language English </div>	<p>Press "▲" or "▼" to select the language and save by ENTER</p>	English/Chinese
Working pages	<div style="border: 1px solid black; padding: 5px; text-align: center;"> Fogging H-20V </div>	<p>After the machine is heated and the DMX signal is not connected, press "▲" or "ENTER" on the panel to start or stop the machine.</p>
	<div style="border: 1px solid black; padding: 5px; text-align: center;"> Timer Interval 5S H-20V </div>	<p>After the machine is heated, the "Preparation" interface is displayed, and when the DMX signal is not connected, by pressing the panel "▲" to multiplex "TIMER", the machine can start scheduled work, and the interface displays the output interval and duration. Press "ENTER" to stop the machine's scheduled work.</p>
Warning pages	<div style="border: 1px solid black; padding: 5px; text-align: center;"> Heating Error 1 </div>	<p>Heating time timeout The machine starts heating from normal temperature. When the heating time exceeds 10 minutes and the machine's heating aluminum temperature value does not reach the preset value, the machine stops working and reports an error, and the display shows "heating failure". After shutting down the machine, troubleshooting and then restarting it will return to normal.</p>
	<div style="border: 1px solid black; padding: 5px; text-align: center;"> Heating Error 2 </div>	<p>High temperature detection When the machine detects that the temperature of the heating aluminum is greater than 400°C or the heating aluminum thermocouple is open, the machine stops working and reports an error, and the display shows "temperature too high". After shutting down the machine, troubleshooting and then restarting it will return to normal.</p>

5.4 DMX Mode & Operation DMX

The Machine H-20V works with a DMX controller.

- Connect the product to a suitable power outlet. Turn the product on.
- Connect a DMX cable from the DMX output of the DMX controller to the DMX input socket on the product.

5.4.1 Starting Address

When selecting a starting DMX address, always consider the number of DMX channels. If you choose a starting address that is too high, you could restrict the access to some of the product's channels.



The starting address of the H-20V can be set within the DMX range of 001–512. It uses 15 or 16 DMX channels, so to ensure full control of all channels, the maximum recommended starting address is 497.



Connect a DMX cable from the DMX output of the DMX controller to the DMX input socket on the product, or press repeatedly “MENU” button until the LCD shows “DMX Address”. Press “▲” or “▼” to set desired DMX starting address.

5.4.2 DMX Mode Menu Map

When the machine connects to DMX, the display will always show DMX starting address, and you can set or change it at any time.



5.4.3 DMX Channel Assignments and Values DMX

16 Channels:

Channel	Function	Value	Description
1	Fog	0- 9	Off
		10 - 255	On
2	Fan Idle Speed	0-128	Off
		129-255	On
3	LED Red	0 - 9	Off
		10 - 255	Dim to bright
4	LED Green	0 - 9	Off
		10 - 255	Dim to bright
5	LED Blue	0 - 9	Off
		10 - 255	Dim to bright
6	Outer LED Amber	0 - 9	Off
		10 - 255	Dim to bright
7	Inner LED Red	0 - 9	Off
		10 - 255	Dim to bright
8	Inner LED Green	0 - 9	Off
		10 - 255	Dim to bright
9	Inner LED Blue	0 - 9	Off
		10 - 255	Dim to bright
10	Inner LED Amber	0 - 9	Off
		10 - 255	Dim to bright
11	LED mix color	0 - 9	Off

		10 - 255	LED mix color
12	LED mix color	0 - 9	Off
		10 - 255	LED mix color
13	LED Auto color	0 - 9	Off
		10 - 255	LED slow to fast
14	Strobe	0 - 9	Off
		10 - 255	LED slow to fast
15	Dimmer	0-9	Off
		10-255	Dim to bright
16	Safety channel	0-49	DMX Invalid operation
		050 - 200	DMX valid operation (After the safety channel is activated, the functions of channels 1-15 can be controlled normally.)
		201 - 255	DMX Invalid operation

Note: The 16-channel mode has one more Safty channel than the 15-channel mode. When using DMX to control the LED, in order to extend the LED life, the LED lighting time will automatically go out after 25 seconds. If you need to light it up again, please change channel 15, set it back to 0 and then raise it to 255.

6 TECHNICAL INFORMATION

6.1 Expected LED Lifespan

LEDs gradually decline in brightness over time, primarily due to heat. Packaged in clusters, LEDs exhibit higher operating temperatures than in ideal, single-LED conditions. For this reason, using clustered LEDs at their fullest intensity significantly reduces the LEDs' lifespan. Under normal conditions, this lifespan can be 40,000 to 50,000 hours. If extending this lifespan is vital, lower the operating temperature by improving the ventilation around the product and reducing the ambient temperature to an optimal operating range. In addition, limiting the overall projection intensity may also help to extend the LEDs' lifespan.

6.2 Maintenance

Drain residual fluid before transport. Steps: Turn off and restart the power, wait for 5 seconds. Repeat this step for 2~3 times.

Do not allow the H-20V to become clogged. Dust build-up reduces light output performance and can cause overheating. This can lead to reduced light source life and increased mechanical wear. After every 40 hours of continuous operation, use a detergent composed of 35% vinegar and 65% distilled water through the system and spray 10-15 times after heat to prevent the accumulation of particulate matter in the heating element. The recommended cleaning procedure is as follows:

- 1) Unplug the product from power.
- 2) Empty all fluid from the machine.
- 3) Add cleaning solution to the tank.

- 4) Connect the product to power and allow it to warm up.
- 5) Run the product in a well-ventilated area until the tank is empty. Do not allow the pump to run dry.
- 6) Refill with fog fluid to continue using the H-20V. Run the machine briefly to clear any cleaning solution from the pump and heater.
- 7) Excessive dust, fluid residue and dirt will degrade performance and cause overheating. Remove dust from air vents with air compressor, vacuum or soft brush. The casing could be cleaned by the damp cloth.



Test-run your TOPCAT®H-20V on a monthly basis to achieve the best performance.

6.3 Storage

Before storing the machine, clean it as described in the cleaning procedure above; however, only follow steps 1 through 5. Do not refill the tank with fog fluid if storing the machine. Cleaning the system prior to storage will help prevent any particles from condensing inside the pump or heater while not in use.

