

X-FORCE

by DJPOWER

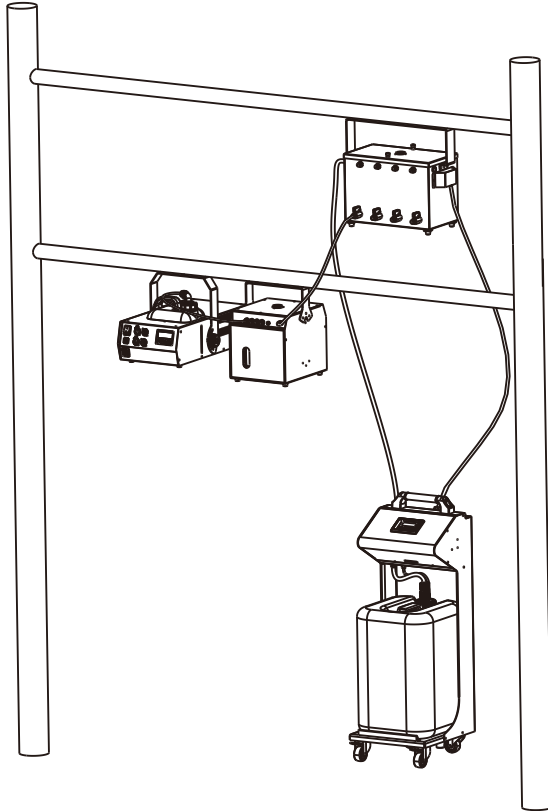

DK-1S

USER MANUAL

GUANGZHOU DJPOWER ELECTRONIC TECHNOLOGY CO.,LTD

1.5.2 Mounting and Rigging

- The product is for indoor use only! To prevent risk of fire or shock, do not expose the product to rain or moisture.
- CAUTION: When transferring product from extreme temperature environments, (e.g. cold truck to warm humid ballroom) condensation may form on the internal electronics of the product. To avoid causing a failure, allow product to fully acclimate to the surrounding environment before connecting it to power.
- Do not mount the product on a flammable surface (linoleum, carpet, wood, paper, carton, plastic, etc.).
- When hanging the Transit liquid tank, always use the safety cable to fix it and keep it horizontal, or it may influence the performance and effects of the effects machines.
- When the rolling cart is placed on the tilted surface, please unscrew the metal plate(as shown in the picture), reverse it and fix the screws again to support the unit.

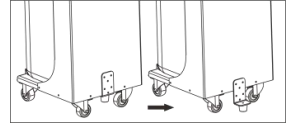

1.5.3 Power and Wiring

- Always make sure that the voltage of the outlet to which you are connecting the product is within the range stated on the decal or rear panel of the product.
- Make sure the power cord is not crimped or damaged.
- Never connect this product to a dimmer pack or rheostat.
- Never disconnect the product from power cord by pulling or tugging on the cord.
- To eliminate unnecessary wear and improve its lifespan, during periods of non-use completely disconnect the product from power via breaker or by unplugging it.

1.5.4 Operation

- Do not operate this product if you see damage to the housing or cables. Have the damaged parts replaced by an authorized technician at once.
- Do not use the product as a space heater.
- Make sure there are no flammable materials close to this product while it is operating.
- The maximum ambient temperature (T_a) is 104 °F (40 °C). Do not operate the product at higher temperatures.
- Wipe up spitted fluid immediately. Moisture – also fluid – can destroy the electric.
- Never carry the product by the power cord or any moving part. Always use the handles of the machine.
- Drain the tank before transporting the product.
- Always disconnect the product from the power source before cleaning.
- In the event of a serious operating problem, stop using the product immediately.
- This product contains no user-serviceable parts. Any reference to servicing in this User Manual will only apply to properly trained, certified technicians. Do not open the housing or attempt any repairs which can lead to damage or malfunction.



Keep this User Manual for future use. If you sell the product, be sure that the purchaser receives this document.

2 INTRODUCTION

2.1 Description

The DK-1S Liquid Supply System is an upgraded version of the DK-1. It is a newly launched product which provides solution for refilling liquids to fog/haze/snow/bubble machines in case the units are mounted high, completely ease the inconvenience of aloft work. It is easy to install, and can supply liquid for maximum 8 units at a time. The product adopts the patented technology of depressurization and reflux, which is easy to install and use. No more taking risks, climbing up and down to fuel the machine!

2.2 Features

- With LCD control panel, easy operation.
- With No-fluid protection function.
- With 25L liquid tank, large storage capacity.
- The maximum conveying height is about 25 meters, and the maximum conveying horizontal distance is about 40 meters
- With LED lights for checking the liquid amount.

2.3 Product Overview

1、DK-1S-A Rolling cart

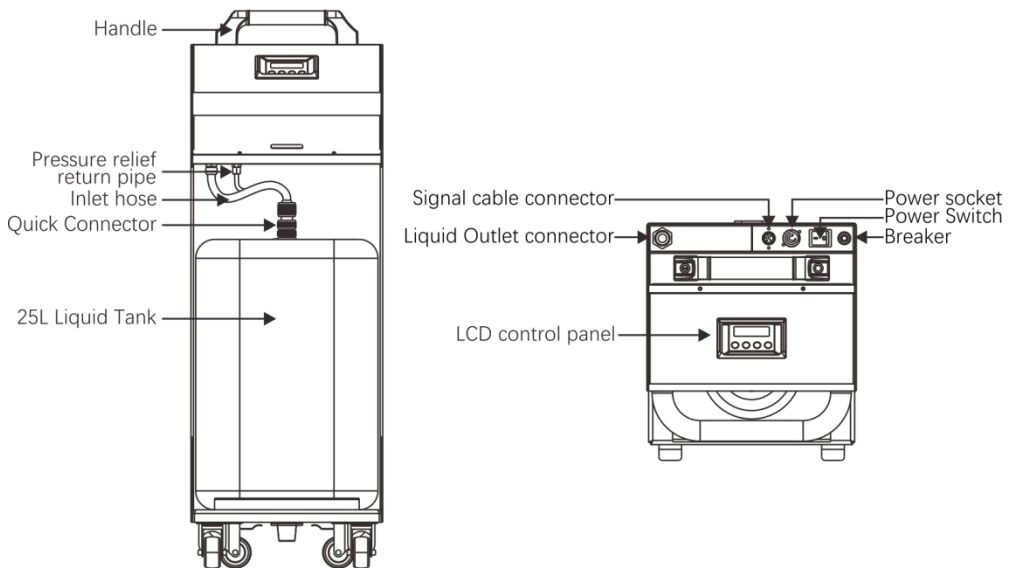

2、DK-1S-B Transit Liquid Tank

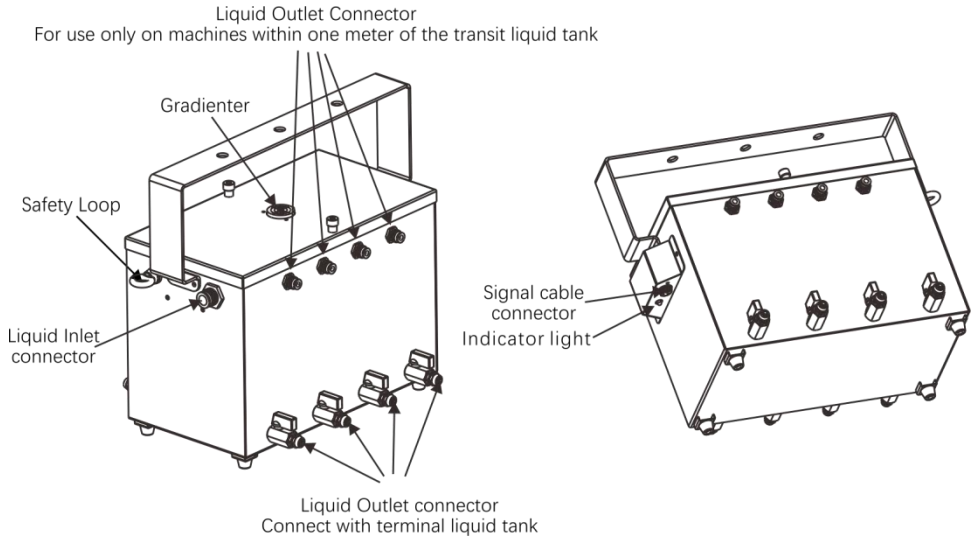

3、DK-1S-C Terminal Liquid tank

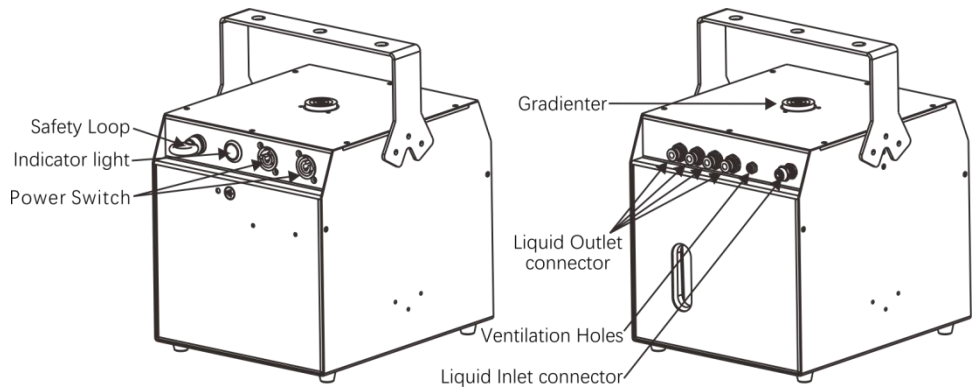

2.4 Product Dimensions

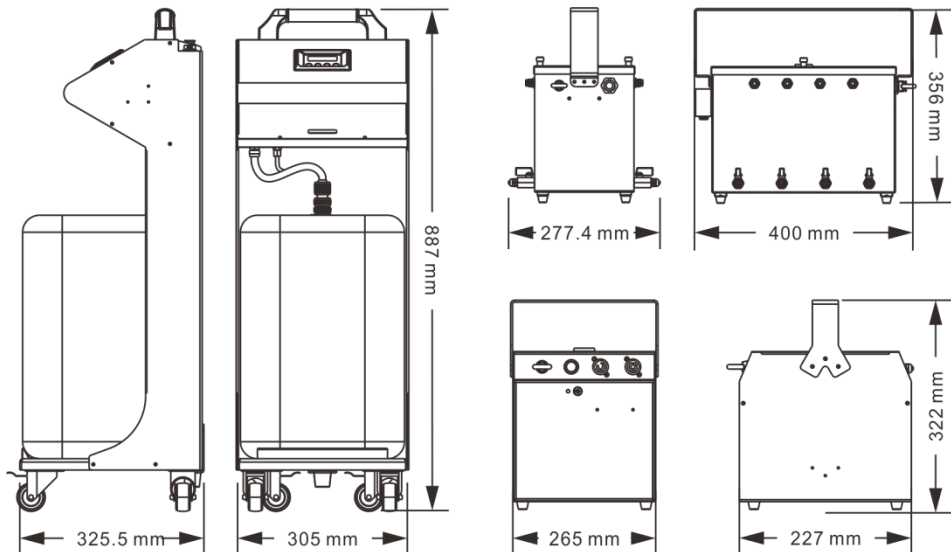

3 TECHNICAL SPECIFICATIONS

3.1 DK-1S-A Rolling Cart

Input Voltage & Rate	AC 100-240 V, 50/60 Hz
Current Limiter Type	Breaker
Current Limiter Specifications	5 A, 250 V
Total Power Consumption	40 W
Liquid tank capacity	25 L
Horizontal	√
Inclined	×
Side mount	×
Hang Upside Down	×
Rigging & Trussing	√
On-device Manual Control	LCD control board
Wireless Control	×
Wired Control	×
Max vertical distance	Apr. 25 m
Consumable	PRO-A/C/J/V/D/P/X
Rolling cart N.W.	17.8 kg
Rolling cart G.W	20.4 kg
Rolling cart size	305 × 325.5 × 887 mm
Rolling cart package size	1015 × 445 × 405 mm

3.2 DK-1S-B Transit Liquid Tank

Transit Liquid Tank N.W.	7.2 kg
Transit Liquid Tank G.W.	8.5 kg
Transit Liquid Tank size	400 × 277.4 × 356 mm
Transit Liquid Tank package size	515 × 315 × 430 mm

3.3 DK-1S-C Terminal Liquid tank

Input Voltage & Rate	AC 100-230 V, 50/60 Hz
Total Power Consumption	50 W
Max vertical distance	Appr. 40 m
Terminal Liquid tank N.W.	7.9 kg
Terminal Liquid tank G.W.	8.7 kg
Terminal Liquid tank size	227 × 265 × 322 mm
Terminal Liquid tank package size	360 × 315 × 400 mm

4 SETUP

4.1 AC Power

The machine has a fixed voltage power supply and can work with an input voltage of AC 220 V-240 V, 50/60 Hz, depending on the specific model.

To determine the product's power requirements (circuit breaker, power outlet, and wiring), use the current value listed on the label affixed to the product's back panel, or refer to the product's specifications chart. The listed current rating indicates the product's average current draw under normal conditions.

 **Always connect the product to a protected circuit (circuit breaker or fuse). Make sure the product has an appropriate electrical ground to avoid the risk of electrocution or fire.**

 **Never connect the product to a rheostat (variable resistor) or dimmer circuit, even if the rheostat or dimmer channel serves only as a 0 to 100% switch.**

4.2 AC Plug

The DK-1S comes with a power input cord terminated with a Lockable power connector on one end. The other end is

- CN plug (CN market, etc.)
- EU plug (EU market, etc.)
- US plug (US market, etc.)

If the power input cord that came with your product has no plug, or if you need to change the plug, use the table below to wire the new plug:

Connection	Wire (China)	Wire (Europe)	Wire (U.S.)
AC Live	Brown	Brown	Black
AC Neutral	Blue	Blue	White

AC Ground	Green/Yellow	Green/Yellow	Green/Yellow
-----------	--------------	--------------	--------------

4.3 Resetting the Breaker

This product is equipped with a resettable breaker. If the breaker trips, all sections of this product will lose power.

- Remove the power cord from mains power.
- Allow unit to cool for 15 minutes.
- After 15 minutes, you may attempt to reset the breaker by pressing the button with your finger.
- Plug the product's power cord into the power outlet and continue using as recommended.

4.4 Mounting

Before mounting the product, read and follow the safety recommendations indicated in the Safety Notes.

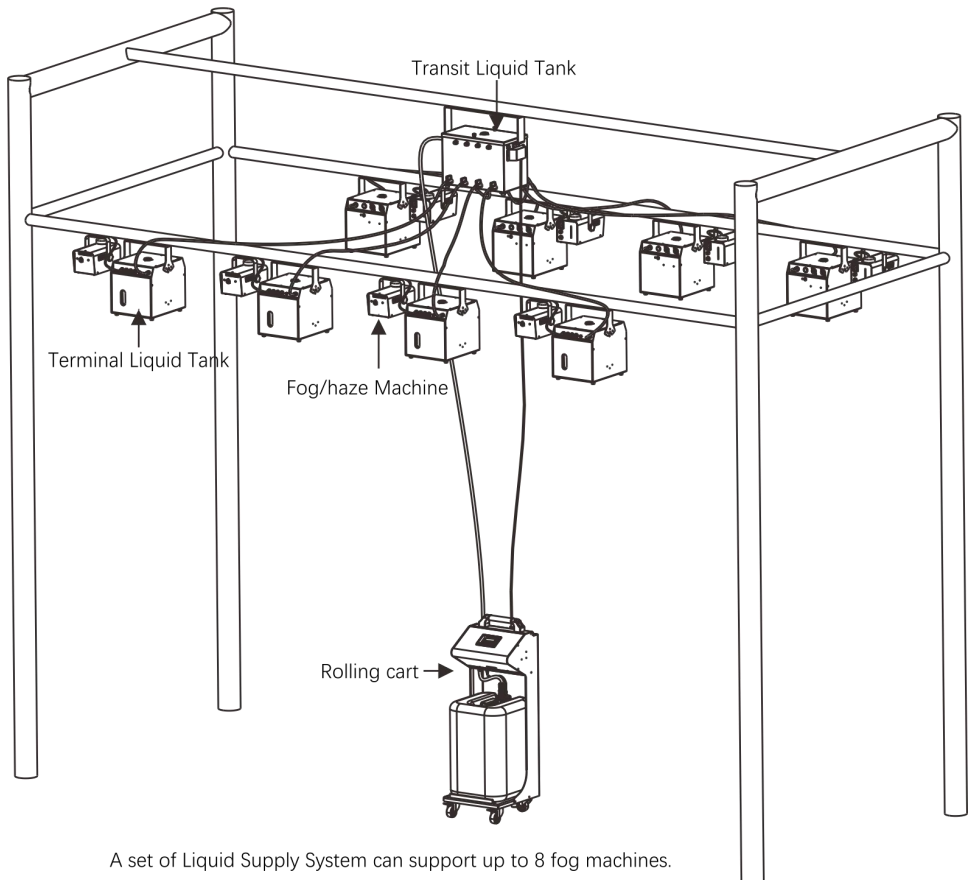

A set of Liquid Supply System can support up to 8 fog machines.

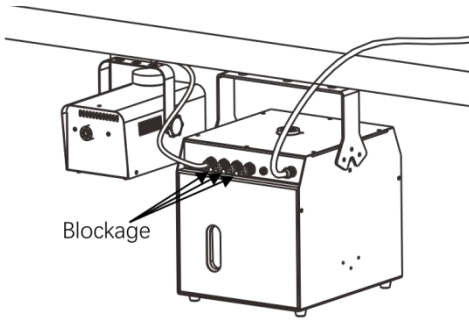

Blockage

When the joint of the terminal liquid tank is not connected to the pipeline, it is necessary to put a blockage, otherwise the liquid will easily overflow.

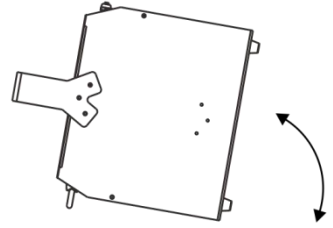

The terminal liquid tank can swing at various angles, the maximum horizontal swing angle is 80°



A set of Liquid Supply System can support up to 8 fog machines. One fog machine is equipped with one terminal liquid tank. The number of terminal liquid tanks can be customized according to requirements. Each Liquid Supply System is equipped with at least 4 terminal liquid tanks, and DK-1S and DK-1S-C.

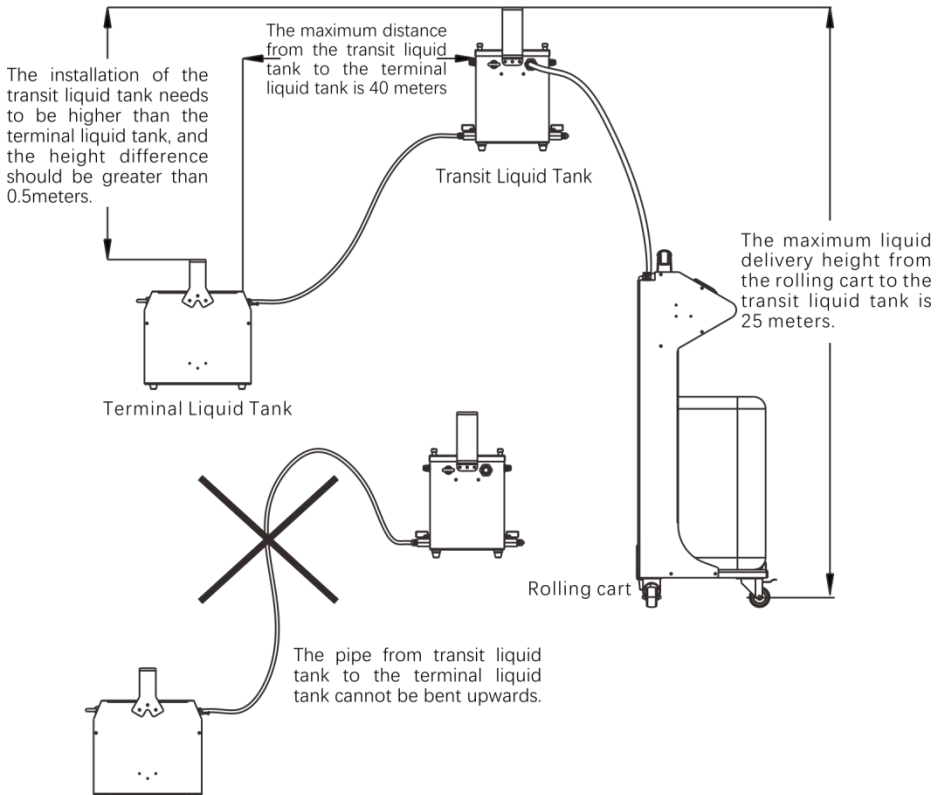

- The maximum distance from the transit liquid tank to the terminal liquid tank is 40 meters, and the maximum liquid delivery height from the rolling cart to the transit liquid tank is 25 meters.
- The installation of the transit liquid tank needs to be higher than the terminal liquid tank, and the height difference should be greater than 0.5 meters.
- The length of the pipeline from the terminal liquid tank to the fog machine shall not be greater than 1 meter.
- When the joint of the terminal liquid tank is not connected to the pipeline, it is necessary to put a blockage, otherwise the liquid will easily overflow.
- The pipe from transit liquid tank to the terminal liquid tank cannot be bent upwards.
- The terminal liquid tank can swing at various angles, the maximum horizontal swing angle is 80°
- When the joint of the terminal liquid tank is not connected to the pipeline, it is necessary to put a blockage, otherwise the liquid will easily overflow.
- The height difference between transit liquid tank and the terminal liquid tank should be greater than 0.5 meters

4.4.1 Orientation

Before mounting the product, read and follow the safety recommendations indicated in the Safety Notes.

4.4.2 Rigging

DJPOWER recommends using the following general guidelines when mounting this product.

- Before deciding on a location for the product, make sure there is easy access to the product for maintenance and programming purposes.
- Make sure that the structure or surface onto which you are mounting the product can support the product's weight (see the Technical Specifications).
- When mounting the product on the floor, make sure that the product and cables are away from people and vehicles.
- When mounting the product overhead, always use a safety cable. Mount the product securely to a rigging point, whether an elevated platform or a truss.

5 OPERATION

5.1 Preparing for Operation

To prepare the DK-1 for operation, perform the following steps.

- After checking that all the parts are intact and complete, position the rolling cart on flat.
- Withdraw the fluid tank from its compartment and remove its cap.
- Fill the fluid to the big tank.
- Place the liquid tank back to its compartment, seal the cap. (Verify that the two plastic fluid hoses attached to the cap are in place and in good condition.)
- After positioning the Transit Liquid Tank and effects machines. (Ensure that the Transit Liquid Tank is placed horizontally.)

- Connect the fluid tube of effects machines to the Transit Liquid Tank through adapters and extended long tube. (Make sure the fluid tube between the machine and the transit liquid tank is not bent or kinked.)
- Link the Signal cable and fluid tube between the Transit Liquid Tank and the 25L tank.
- Always connect the product to a grounded circuit. Before power on, make sure it is connected with the rated voltage.





Note: Only one type of liquid can be filled into the big tank at one time. Please make sure that the correct fluid is being used and are conveyed to the effect machines.

Once the Host (Rolling Cart) is switched ON, it would detect the liquid inside Transit Tank automatically and supply liquid to it when the liquid level is low.

5.2 On-device Control Panel



To access the control panel functions, use the four buttons located underneath the LCD display.





Button				
Function	Fluid Sensor	Set the fluid type based on the fluid in the tank	Keypad tone	LED Light

5.3 On-device Control Mode & Operation

5.3.1 Menu Map

	LCD Display	Description	Parameter Range
Welcome Pages			
	Fluid Sensor ON Enough Fluid	Press  to turn ON/OFF the fluid sensor to detect the fluid amount inside the 25L liquid tank.	ON/OFF
Settings Page	Fog Fluid Enough Fluid	Keep Pressing  to unlock and set the fluid type on the display based on the fluid inside the big tank. In case several units are being used, this can help the operator know which fluid to be refilled easily. (Note: Symbol ★ means locked and disappears when unlocked)	Fog fluid/ Haze fluid/ Fog jet fluid/ Bubble fluid/ Snow fluid

	Keypad Tone ON Enough Fluid	Press  to turn ON/OFF the keypad tone.	ON/OFF
	LED light ON Enough Fluid	Press  to turn ON/OFF the LED light which light the Liquid tank so that user can check the liquid amount in the darkness.	ON/OFF
Working Page	* Fog Jet Fluid Enough Fluid	Fluid is enough.	
Error and warning Page	* Fog Jet Fluid No Fluid	While showing this page, please refill fluid to the 25L liquid tank.	
	* Fog Jet Fluid System Fault	While the LCD display showing this page, please plug in signal cable.	

Note:

1. In case there is no signal connecting to the Rolling Cart, the LCD display will show “System Fault” instead of “Enough Fluid”.
2. The LCD display will back to working page within 5s after setting the relevant information.

5.4 Fluid Sensor

This machine uses software-based fluid sensor to detect whether there is fluid inside tube so as to protect the pump from being damaged. Turn on the “Fluid Sensor” to activate “No Fluid Protection” function.

5.4.1 Trigger “No-Fluid Protection”

When the Fluid Sensor is ON, the software-based “no-fluid protection” function will be activated. After the program continues to detect the machine working with no fluid inside the tube for about 1 minute, the pump-shutoff will be activated with the flickering warning page showing on the screen.

5.4.2 Clear “No-Fluid Protection” Warning

When the machine is under the no-fluid protection, after refilling the fluid, there are two ways to clear the warning.

- Turn off “Fluid Sensor” in the menu.
- Power Off the machine and restart it.